

Product manual

FlexGripper-Clamp

IRB 660/460



ABB

Product manual
FlexGripper-Clamp

Document ID: 3HAC040630-002

Revision: -

The information in this manual is subject to change without notice and should not be construed as a commitment by ABB. ABB assumes no responsibility for any errors that may appear in this manual.

Except as may be expressly stated anywhere in this manual, nothing herein shall be construed as any kind of guarantee or warranty by ABB for losses, damages to persons or property, fitness for a specific purpose or the like.

In no event shall ABB be liable for incidental or consequential damages arising from use of this manual and products described herein.

This manual and parts thereof must not be reproduced or copied without ABB's written permission.

Additional copies of this manual may be obtained from ABB.

© Copyright 2011 ABB All rights reserved.

ABB Robotics
CNAUS
Shanghai, China

Overview	5
1 Safety	7
1.1 Introduction	7
1.2 General safety information	8
1.2.1 Safety in the manipulator system	8
1.2.2 Safety risks	9
1.2.2.1 Safety risks during installation and service work on the FlexGripper	9
1.2.2.2 Safety risks related to tools/workpieces	10
1.2.2.3 Safety risks related to high speed	11
1.2.2.4 Safety risks during operational disturbances	12
1.2.2.5 Risks associated with live electric parts	13
1.2.3 Safety actions	14
1.2.3.1 Safety fence dimensions	14
1.2.3.2 Fire extinguishing	15
1.2.3.3 Safe use of the FlexPendant	16
1.3 Safety related instructions	17
1.3.1 Safety signals, general	17
1.3.2 Safety symbols on the FlexGripper labels	19
1.3.3 Safety guidelines	20
2 FlexGripper-Clamp	21
2.1 Specification	21
2.2 Mechanical structure & working principle	23
2.2.1 General	23
2.2.2 Main frame	24
2.2.3 Clamp unit	25
2.2.4 Hook unit	27
2.3 Installation and commissioning	28
2.3.1 Overview	28
2.3.2 Unpacking	29
2.3.3 Adjustment	31
2.3.4 Mounting the FlexGripper-Clamp	32
2.3.5 Commissioning	35
2.4 Maintenance	48
2.4.1 General	48
2.4.2 Regular Inspection of FlexGripper-Clamp	49
2.4.3 Regular replacement	50
2.5 Repair	51
2.5.1 Instruction	51
2.5.2 Cylinder	52
2.5.2.1 Replacing the moving plate cylinder	52
2.5.2.2 Replacing the cylinder of hook	54
2.5.3 Magnetic proximity switch	57
2.5.4 Sensors	59
2.5.5 Solenoid valve	60
2.5.6 Dress cable	61
2.6 Trouble shooting	62
2.6.1 Start-up failures	62
2.6.2 Gripper not responding	63
2.6.3 Wrong movement	64
2.6.4 Low performance	65
2.6.5 Problem jogging the gripper	66

Table of Contents

2.6.6 Oil stains on gripper	67
2.6.7 Mechanical noise	68
2.6.8 Workpiece drop on power down	69
2.6.9 Workpiece drop on air down	70
2.6.10 No Input signal detected.	71
2.7 Decommissioning	72
2.7.1 Introduction	72
2.7.2 Environmental information	73
2.8 Ware part	74
2.9 Spare parts	75
2.10 Circuit diagram	83
2.10.1 Electrical circuit	83
2.10.2 Pneumatic circuit	94

3 FlexGripper UI 97

3.1 Software installation.	98
3.1.1 Installing FlexGripper UI FlexPendant application	98
3.1.2 I/O signal configuration	100
3.1.3 Back-up and I-Start	102
3.2 Operation.	103
3.2.1 FlexGripper UI main interface	103
3.2.2 Tool handle	104
3.2.2.1 FlexGripper function test	104
3.2.2.2 TCP edit	108
3.2.3 Tune	112
3.2.3.1 Position Tune	112
3.2.3.2 Work object tune	114
3.2.3.3 Test run	115
3.2.4 Production.	117
3.2.4.1 Production monitor	117
3.2.4.2 Setup	118
3.3 Trouble shooting	121

Overview

About this manual

This manual provides instructions for the FlexGripper-Clamp. Each chapter concerning the FlexGripper-Clamp contains information on:

- mechanical structure & working principle
- mechanical /electrical installation
- maintenance
- repair
- trouble shooting
- spare parts

Read through this document carefully, especially the sections about safety, before you start to unpack, install and use the FlexGripper-Clamp.

Usage

This manual should be used during:

- installation
- operation
- maintenance work
- repair work

Who Should Read This Manual?

This manual is intended for:

- operators
- installation personnel
- repair and maintenance personnel

Prerequisites

The reader should be:

- familiar with industrial robots and the relevant terminology
- familiar with the equipment
- skilled in mechanical & electrical installation/maintenance/repairs

Organization of Chapter

The manual is organized in to the following chapters:

Chapter	Contents
1.	Safety
2.	FlexGripper-Clamp
3.	FlexGripper UI

Continues on next page

Overview

Continued

Reference

Reference	Document ID
Product manual - IRB 660	3HAC025755-001
Product manual - IRB 460	3HAC039611-001
Product manual - IRC5 Robot Controller	3HAC021313-001

Revision

Revision	Description
-	First edition

1 Safety

1.1. Introduction

Overview

The safety information in this manual is divided into two categories:

- General safety aspects, important to attend to before performing any service work on the FlexGripper. These are applicable for all service work and are found in *General safety information on page 8*.
- Specific safety information, pointed out in the procedure when the danger is imminent. How to avoid and eliminate the danger is either detailed directly in the procedure, or further detailed in separate instructions, found in *Safety related instructions on page 17*.



NOTE!

This manual includes only the safety information related to this product.

The FlexGripper can be used together with IRB660 or IRB460. Please refer the Robot and IRC5 Controller manuals for more details on safety.

1 Safety

1.2.1. Safety in the manipulator system

1.2 General safety information

1.2.1. Safety in the manipulator system

Validity and responsibility

The information does not cover how to design, install and operate a complete system, nor does it cover all peripheral equipment, which can influence the safety of the total system. To protect personnel, the complete system must be designed and installed in accordance with the safety requirements set forth in the standards and regulations of the country where the manipulator is installed.

The users of ABB products are responsible for ensuring that the applicable safety laws and regulations in the country concerned are observed, and that the safety devices necessary to protect people working with the system are designed and installed correctly.

Personnel working with manipulators must be familiar with the operation and handling of the industrial manipulator, as described in the following documents:

- Operating Manual - IRC5 with FlexPendant (M2004)
- Product Manual

Connection of external safety devices

Apart from the built-in safety functions, the manipulator is also supplied with an interface for the connection of external safety devices. Via this interface, an external safety function can interact with other machines and peripheral equipment. This means that control signals can act on safety signals received from the peripheral equipment as well as from the manipulator.

Limitation of liability

Any information given in this manual regarding safety must not be construed as a guarantee by ABB that the industrial manipulator will not cause injury or damage, even if all safety instructions are complied with.

Related information

Type of information	Detailed in document	Section
Installation of safety devices	Product manual for the manipulator	Installation and commissioning
Changing operating modes	Operating manual - IRC5 with FlexPendant	Operating modes
Restricting the working space	Product manual for the manipulator	Installation and commissioning

1.2.2. Safety risks

1.2.2.1. Safety risks during installation and service work on the FlexGripper

Overview

This section includes information on general safety risks to be considered when performing installation and service work on the FlexGripper.

General risks during installation and service

- The instructions in the Product manual in the section *Installation and commissioning on page 28* must always be followed.
 - Emergency stop buttons must be positioned in easily accessible places so that the manipulator can be stopped quickly.
 - Those in charge of operations must make sure that safety instructions are available for the installation in question.
 - Those who install the FlexGripper must have the appropriate training for the manipulator system in question and in any safety matters associated with it.
-

Nation/region specific regulations

To prevent injuries and damage during the installation of the manipulator system, the regulations applicable in the country concerned and the instructions of ABB manipulatorics must be complied with.

1 Safety

1.2.2.2. Safety risks related to tools/workpieces

1.2.2.2. Safety risks related to tools/workpieces

Safe handling

It must be possible to safely turn off tools, such as milling cutters. Make sure that guards remain closed until the cutters stop rotating. It should be possible to release parts manually (valves).

Safe design

FlexGrippers are designed so that they retain workpieces in the event of a power failure or a disturbance to the controller.

1.2.2.3. Safety risks related to high speed



WARNING!

Particular care must be taken with the FlexGripper-Clamp.

Risk of gripped workpiece uncontrolled gravity drop during high speed movement.

1 Safety

1.2.2.4. Safety risks during operational disturbances

1.2.2.4. Safety risks during operational disturbances

General

- The industrial manipulator is a flexible tool that can be used in many different industrial applications.
- All work must be carried out professionally and in accordance with the applicable safety regulations.
- Care must be taken at all times.

Qualified personnel

- Corrective maintenance must only be carried out by qualified personnel who are familiar with the entire installation as well as the special risks associated with its different parts.

Extraordinary risks

If the working process is interrupted, extra care must be taken due to risks other than those associated with regular operation. Such an interruption may have to be rectified manually.

1.2.2.5. Risks associated with live electric parts

Voltage related risks, general

- Although trouble shooting may, on occasion, have to be carried out while the power supply is turned on, the manipulator must be turned off (by setting the main switch to OFF) when repairing faults, disconnecting electric leads and disconnecting or connecting units.
- The main supply to the manipulator must be connected in such a way that it can be turned off outside the manipulator's working space.

Voltage related risks, controller IRC5

A danger of high voltage is associated with the following parts:

- The mains supply/mains switch
- The transformers
- The power unit
- The control power supply (230 VAC)
- The rectifier unit (400-480 VAC and 700 VDC. Note: Capacitors!)
- The drive unit (700 VDC)
- The drive system power supply (230 VAC)
- The service outlets (115/230 VAC)
- The customer power supply (230 VAC).
- The power supply unit for tools, or special power supply units for the machining process.
- The external voltage connected to the control cabinet remains live even when the manipulator is disconnected from the mains.
- Additional connections
- Be aware of stored electrical energy (DC link, Ultra Cap unit) in the controller.
- Units inside the controller, for example I/O modules, can be supplied with power from an external source.

Voltage related risks, manipulator

A danger of high voltage is associated with the manipulator in:

- The power supply for the motors (up to 800 VDC)
- The user connections for tools or other parts of the installation (max. 230 VAC, see chapter Installation and commissioning in the Product manual).

Voltage related risks, tools, material handling devices and so on

Tools, material handling devices and so on may be live even if the manipulator system is in the OFF position. Power supply cables which are in motion during the working process may be damaged.

1 Safety

1.2.3.1. Safety fence dimensions

1.2.3. Safety actions

1.2.3.1. Safety fence dimensions

General

Install a safety cell around the manipulator and the FlexGripper to ensure safe FlexGripper installation and operation.

Dimensioning

Dimension the fence or enclosure to enable it to withstand the force created if the load being handled by the FlexGripper is dropped or released at maximum speed.

1.2.3.2. Fire extinguishing



NOTE!

Use a CARBON DIOXIDE (CO₂) extinguisher in the event of a fire in the manipulator system (manipulator or controller)!

1 Safety

1.2.3.3. Safe use of the FlexPendant

1.2.3.3. Safe use of the FlexPendant



NOTE!

The enabling device is a push-button located on the side of the FlexPendant which, when pressed half way in, takes the system to MOTORS ON. When the enabling device is released or pushed all the way in, the manipulator is taken to the MOTORS OFF state.

To ensure safe use of the FlexPendant, the following must be implemented:

- The enabling device must never be rendered inoperative in any way. During programming and testing, the enabling device must be released as soon as there is no need for the manipulator to move. The programmer must always bring the FlexPendant with them, when entering the manipulator's working space. This is to prevent anyone else taking control of the manipulator without the programmer being aware of it.

Enabling device

The enabling device is a manually operated constant pressure push-button which, when continuously activated in one position only, allows potentially hazardous functions but does not initiate them. In any other position, hazardous functions are stopped safely. The enabling device is of a specific type where you must press the push-button only half-way to activate it. In the fully in and fully out positions, manipulator operation is impossible.

Hold-to-run function

The hold-to-run function allows movement when a button connected to the function is actuated manually, and immediately stops any movement when released. The hold-to-run function can only be used in manual mode. How to operate the hold-to-run function is detailed in the Operating manual - IRC5 with FlexPendant.

1.3 Safety related instructions

1.3.1. Safety signals, general



General

This section specifies all the dangers that may arise from performing the work detailed in the manual. Each danger is detailed in its own section consisting of:

- A caption specifying the danger level (DANGER, WARNING or CAUTION) and the type of danger.
- A brief description of what will happen if the operator/service personnel do not eliminate the danger.
- An instruction of how to eliminate the danger to facilitate performing the activity at hand.

Danger levels

The table below defines the captions specifying the danger levels used throughout this manual.





Symbol	Designation	Signification
	DANGER	Warns that an accident will occur if the instructions are not followed, resulting in a serious or fatal injury and/or severe damage to the product. It applies to warnings that apply to danger with, for example, contact with high voltage electrical units, explosion or fire risk, risk of poisonous gases, risk of crushing, impact, fall from height, etc.
 en1011002	WARNING	Warns that an accident may occur if the instructions are not followed, that can lead to serious injury, possibly fatal, and/or great damage to the product. It applies to warnings that apply to danger, for example, contact with high voltage electrical units, explosion or fire risk, risk of poisonous gases, risk of crushing, impact, fall from height and so on.
 en1011003	ELECTRIC SHOCK	The electrocution or electrical shock symbol indicates electrical hazards which could result in severe personal injury or death.

Continues on next page

1 Safety

1.3.1. Safety signals, general

Continued

Symbol	Designation	Signification
 en1011004	CAUTION	Warns that an accident may occur if the instructions are not followed that can result in injury and/or damage to the product. It also applies to warnings of risks that include burns, eye injury, skin injury, hearing damage, crushing or slipping, tripping, impact, fall from height, etc. Furthermore, it applies to warnings that include function requirements when fitting and removing equipment, where there is a risk of damaging the product or causing a breakdown.
 en1011005	ELECTROSTATIC DIS- CHARGE(ESD)	The electrostatic discharge (ESD) symbol indicates electrostatic hazards which could result in severe damage to the product.
 en1011006	NOTE	Note symbols alert you to important facts and conditions.
 en1011008	TIP	Tip symbols direct you to specific instructions, where to find additional information or how to perform a certain operation in an easier way.

1.3.2. Safety symbols on the FlexGripper labels

Introduction to labels

This section describes safety symbols used on labels (stickers) on the FlexGripper. Symbols are used in combinations on the labels, describing each specific warning. The descriptions in this section are generic, the labels can contain additional information such as values.

Types of labels

Both the manipulator and the FlexGripper are marked with several safety and information labels, containing important information about the product. The information is useful for all personnel handling the FlexGripper system, for example during installation, service, or operation. The safety labels are language independent, they only use graphics.

Symbols on safety labels

Symbol	Description
 en1015001	Heat Risk of heat that can cause burns.

1.3.3. Safety guidelines

Safety guidelines while working with FlexGripper

- See the IRB 660 or IRB 460 Product manual for information on safety.
- All persons working in the system must be sufficiently trained. Incorrect installation and/or use can cause injuries to persons and/or damage to equipment.
- Damaged or broken equipment can result in a risk to safety.
- Do not continue to work with the FlexGripper if you find any fault in any parts of it.
- Do not over power the pneumatic devices.
- Use pressure relief valves.
- Repair any air leaks immediately.
- Wear safety glasses when working with pneumatic cylinders. Maintenance, assembling, adjustments and other works on the FlexGripper, such as: replacement of pneumatic cylinders , should only be implemented by skilled and qualified workers, when the FlexGripper is not under air-pressure.
- It should be possible to release parts by manual operation (valves).
- Do not touch the FlexGripper while it is connected to air pressure.
- While assembling, adjusting and working on the FlexGripper, it is mandatory to implement safety regulations so that no fingers or other body parts are in proximity to the moving parts of the FlexGripper. There is risk and danger of injury.
- Do not use temporary arrangements to make the FlexGripper work. This may lead to severe damage.
- Ensure all the bolts have been tightened before starting any operation after maintenance work.
- Ensure no foreign material is lying on the FlexGripper before starting any operation.
- During operation the FlexGripper must be protected by fixed or interlocking guards according to the safety laws and regulations in the country concerned.
- It should not be possible to reach any moving parts when the Flexgripper is operating and the safety guards are fenced and interlocked.

2 FlexGripper-Clamp

2.1. Specification



NOTE!

This section describes products the ABB FlexGripper-Clamps can lift and the ABB FlexGripper-Clamp specifications. Users can themselves judge if their products can be lifted by ABB FlexGripper-Clamps accordingly.

This FlexGripper-Clamp handles cardboard boxes, paper tray packages, and buckets and so on. which must have a dense and smooth surface, and a rigid structure on which the clamp can grip.

Storage conditions

Ambient temperature	0° C (32° F) - 55° C (131° F)
Relative humidity	Maximum 90%
Explosive environments	Not permitted

Operating conditions

Ambient temperature	5° C (41° F) - 50° C (122° F)
Relative humidity	Maximum 90%
Explosive environments	Not permitted

FlexGripper weight

FlexGripper type	Weight
1-zone	45 kg
2-zone	80 kg

Continues on next page

2 FlexGripper-Clamp

2.1. Specification

Continued

FlexGripper size

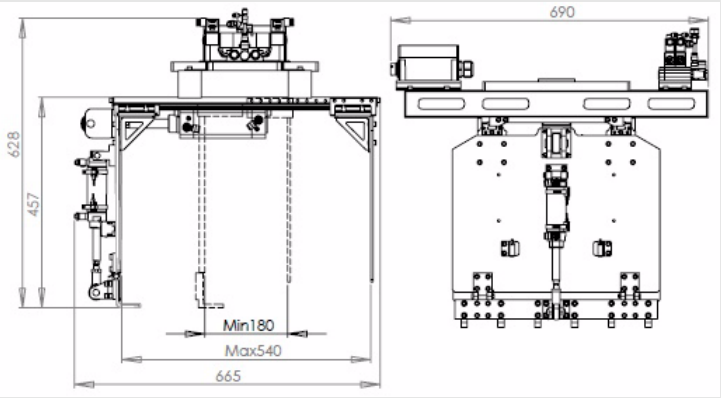
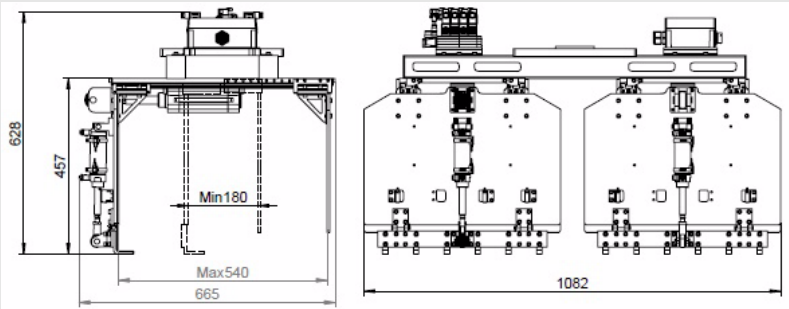
FlexGripper type	Size
1-zone	 <p>en10110623</p>
2-zone	 <p>en10110623</p>

Product specification

Type	Case height range	Case length range	Case width range	Max. weight per lift	Handled products
1-zone	150 – 330 mm	200 - 650 mm	200 - 500 mm	40 kg	1-2
2-zone	150 – 330 mm	200 -1200 mm	200 - 500 mm	60 kg for IRB 660	1-5
	150 – 330 mm	200 -1200 mm	200 - 500 mm	30 kg for IRB 460	1-5



NOTE!

Due to variations in size, weight, design, surface, rigidity, porosity and centre of gravity, please judge if your products can be lifted by ABB FlexGrippers according to the product specifications.

2.2 Mechanical structure & working principle

2.2.1. General

The FlexGripper-Clamp lifts products using plates and a hook. It secures the products by pressing the moving plate towards the stationary plate and supporting the products bottom edge with the small hook.

The action of the moving plate is controlled by a pneumatic cylinder with compressed air (4-6 bar). The pressure regulator on the FlexGripper can adjust the air pressure of the pneumatic system.

The FlexGripper-Clamp has two different types of product, as shown below:

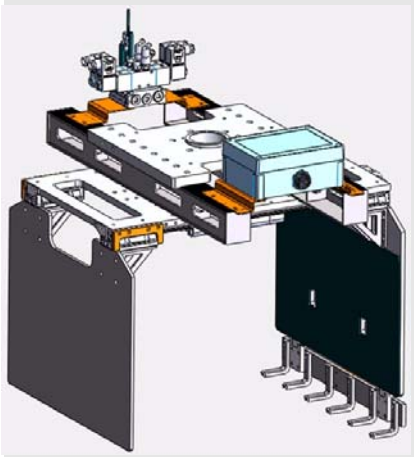
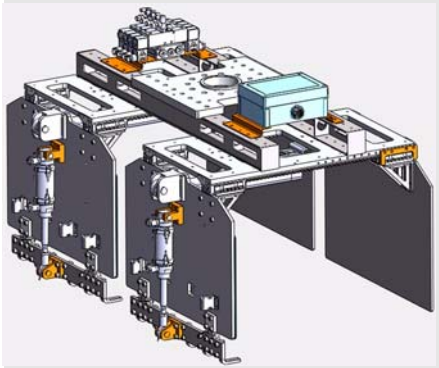
Product	Description	Info/Illustration
1-zone	Consists of one clamp unit and one hook unit. Each unit can be controlled independently by the corresponding pneumatic cylinder.	 en1011026
2-zone	Consists of two clamp units and two hook units. Each unit can be controlled independently by the corresponding pneumatic cylinder.	 en1011027

The two products have the same control principle. FlexGripper-Clamp 2 has two separately controlled moving plates with hooks, in case products processed by different zones need to be picked up or placed down at different times.

2 FlexGripper-Clamp

2.2.2. Main frame

2.2.2. Main frame

The FlexGripper-Clamp mainly consists of a flange, valve unit, terminal box, beam, the clamp unit and the hook unit.

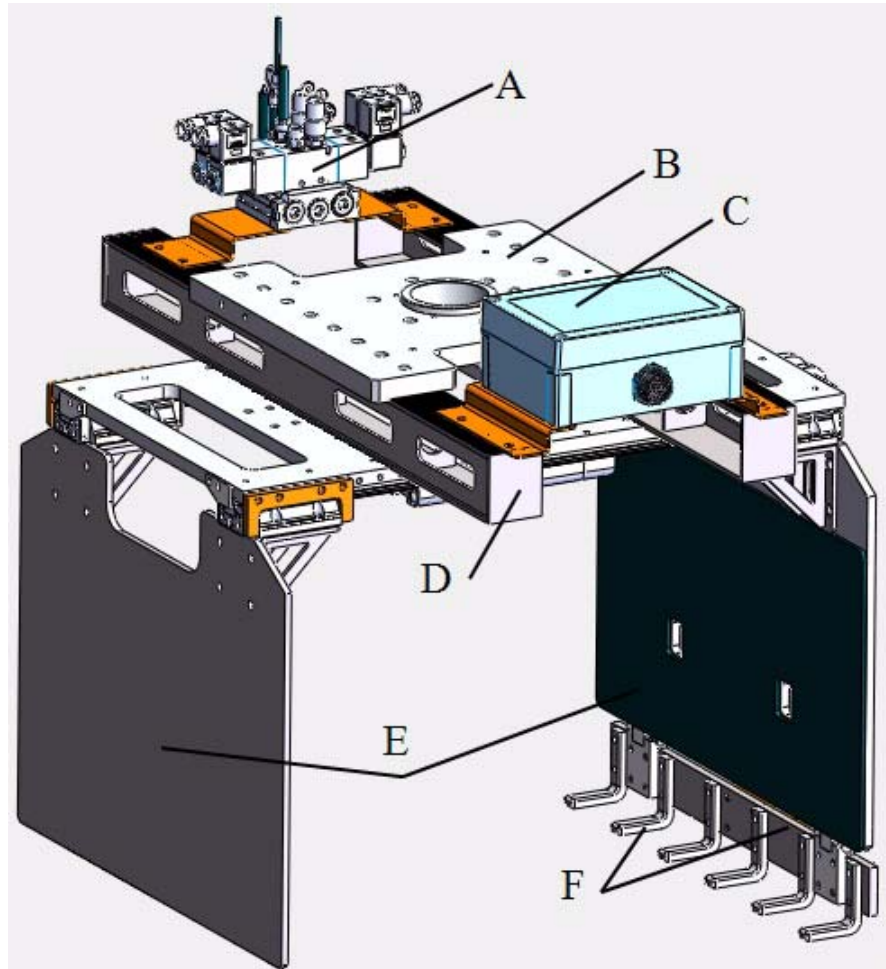

en1011028

Figure 2.1 Main frame of the FlexGripper-Clamp

Pos	Part	Description
A	Valve unit	Controls compressed air inlet and outlet of pneumatic cylinders.
B	Flange	Used to install the FlexGripper to the robot wrist.
C	Terminal box	Signals connections for the FlexGripper.
D	Beam	Fixes the pressure regulator, valve unit and terminal box. Connects the flange and clamp unit.
E	Clamp unit	Grips products and can be adjusted according to the products size.
F	Hook unit	Inserted under the product bottom to support the product.

2.2.3. Clamp unit

The FlexGripper-Clamp uses one moving and one stationary plate (1-zone FlexGripper) or two moving and two stationary plates (2-zone FlexGripper) to grip products.

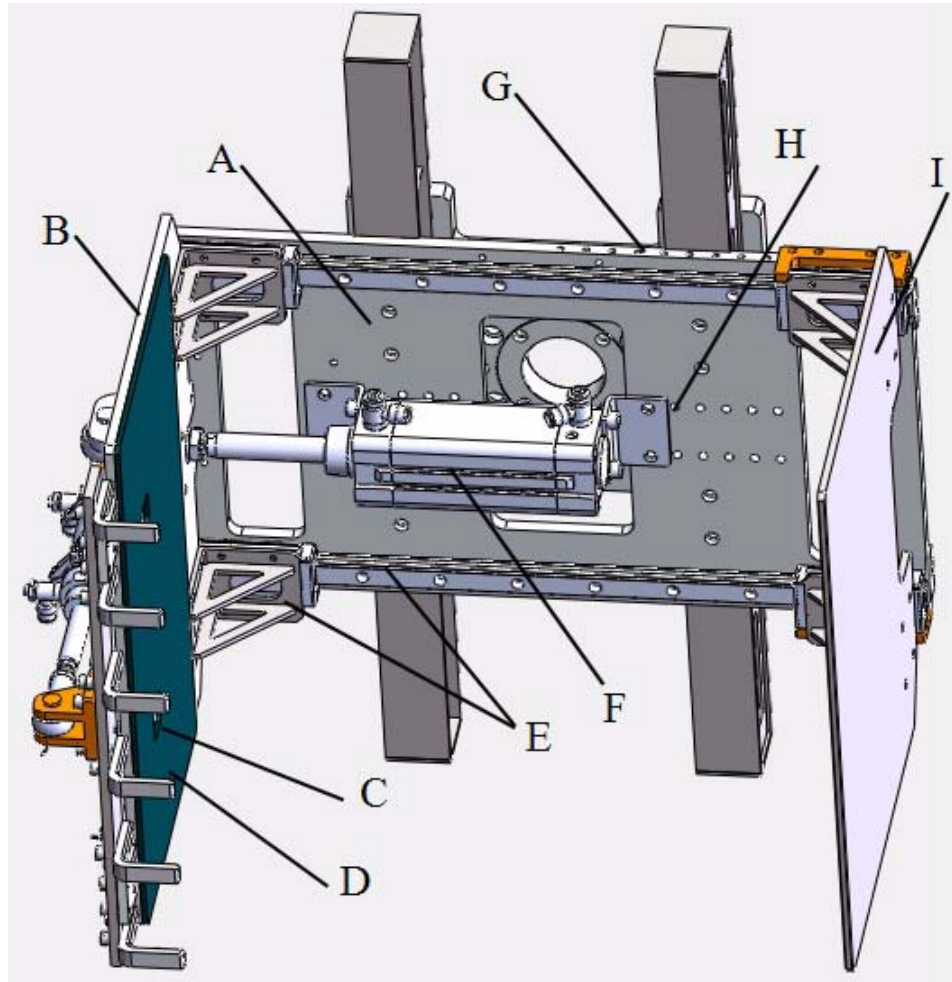

en1011029

Figure 2.2 Bottom view of the clamp unit

Pos	Part	Description
A	Base plate	Fixs the moving and stationary plates. The pneumatic cylinder is mounted on it.
B	Moving plate	The plate can be moved to adjust the distance between the two plates.
C	Mounting place of the photoelectric sensor	Used to mount a photoelectric sensor to detect if the product is picked or not. FlexGripper-Clamp 1 has two sensor mounting places on the moving plate. FlexGripper-Clamp 2 has four sensor mounting places on each moving plate. Totally five sensors are installed on FlexGripper-Clamp 2 by default, the mounting location depends on the size of the products.
D	Rubber pad	Increases the friction force between the plate and the products.

Continues on next page

2 FlexGripper-Clamp

2.2.3. Clamp unit

Continued

Pos	Part	Description
E	Linear guide	The moving plates are mounted on it and move along it.
F	Pneumatic cylinder	Drives the moving plate.
G	Adjustment holes of the stationary plate	Can be used to adjust the mounting location of the stationary plate and then adjust the distance between two plates.
H	Mounting holes of the pneumatic cylinder	Can be used to adjust the mounting location of the cylinder and then adjust the distance between two plates.
I	Stationary plate	The plate keeps stationary.

2.2.4. Hook unit

The cylinder on the moving plate can adjust the hook to open or close. When lifting products, the small hook is inserted under the product in order to hold it during the lift. Before the FlexGripper puts the product down, the hook pulls out from the bottom of the product.

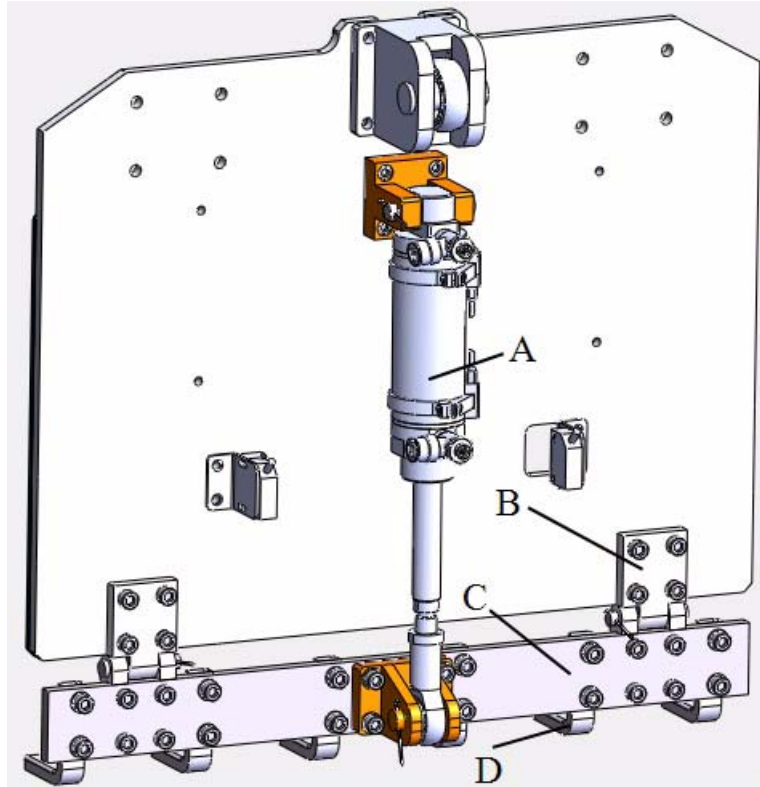

en1011030

Figure 2.3 Hook unit

Pos	Part	Description
A	Pneumatic cylinder	Adjusts the hook tilting angle
B	Hinge	Fixs the hook on the moving plate
C	Hook base	Fixs and supports the hooks
D	Hook fingers	Supports the product bottom with 6 fingers at 80mm intervals.

2 FlexGripper-Clamp

2.3.1. Overview

2.3 Installation and commissioning

2.3.1. Overview

This instruction is primarily intended for use when unpacking and installing the gripper for the first time. It also contains information useful during later installation of the FlexGripper.

The FlexGripper was packed by the standard of sea transportation, land transportation and air transportation on delivery.



NOTE!

Lifting should be done by four people or by a crane.

Do not hold the solenoid valves, terminal box or connectors when lifting the gripper.

2.3.2. Unpacking



NOTE!

Only 24V power is used in FlexGripper.

Short circuit protection should be implemented by a fuse in the control cabinet by the customer.

Inspection

The FlexGripper-Clamp is wrapped in a carton. Be sure to put the package upper face up. Open the package and check for any visible transport damage. If the FlexGripper is damaged, contact ABB.

Packing list

Check the following item list in the standard delivery package before proceeding with actual installation of the FlexGripper.

No.	Item	Description
A	Flange	
B	Screws	For IRB460: 6x M10 screws to install the flange to the robot wrist; 16x M6 screws to mount the flange to the FlexGripper For IRB660: 11x M12 screws to install the flange to the robot wrist; 16x M6 screws to mount the flange to the FlexGripper
C	Preassembled FlexGripper	
D	Cables	Compressed air hose in blue. Signal cable in green. For IRB 460: circular connector; For IRB 660: harting connector. Black corrugated pipe as cable protection
E	Cable bracket	
F	CD	Including: one product manual one spare parts list

Continues on next page

2 FlexGripper-Clamp

2.3.2. Unpacking

Continued



NOTE!

If the FlexGripper is to be installed, open the package and take out the flange first and keep the FlexGripper in the box for the convenience of later installation.

If the FlexGripper is not to be installed directly, it must be stored. For storage conditions for the FlexGripper, see *Storage conditions on page 21*.

Pre-requisites for mounting

The checklist below details items that should be observed before the actual installation of the FlexGripper.

1. Visually inspect the FlexGripper to make sure it is not damaged.
2. Make sure the expected operating environment of the FlexGripper conforms to the specifications described in *Operating conditions on page 21*.
3. Make sure the area around the robot wrist has no particles that would impede the installation of the FlexGripper or be dangerous to the operator.



DANGER!

Before commencing any service work, be sure all the safety clauses have been strictly observed!

Make sure that the power is off before starting any work.



NOTE!

ABB recommend that air connected to the FlexGripper should be: 4-6 bar, filtered, non-lubricated.

Recommended standard tightening torque

For the torque values needed during installation, please see the following.

The table below specifies the recommended standard tightening torque for oil-lubricated allen head screws (recommended class 12.9).

Dimension	Tightening torque (Nm) Class 12.9, oil-lubricated
M5	6
M6	10
M8	24
M10	47
M12	82
M16	200

2.3.3. Adjustment

On delivery, the width is set wide enough to make mounting of the FlexGripper possible.

If needed, please refer to the following instructions to adjust the width between two plates according to the size of the product.

For the correct torque values, see *Recommended standard tightening torque on page 30*.

Adjustment instructions



DANGER!

Turn off all electric power and pneumatic pressure supplies to the gripper!

No	Action	Info/Illustration
1.	<p>The distance between two plates can be adjusted in two ways:</p> <ul style="list-style-type: none"> Adjust the mounting location of the pneumatic cylinder. 24 mounting screw holes (20mm interval) on the base plate can be used to adjust the cylinder installation location. In this way, distance between two plates can be adjusted by 20mm, 40mm, 60mm, 80mm or 100mm. To mount the pneumatic cylinder, use 4xM8 screws. Adjust the mounting location of the stationary plate. In the outward side of the beam, 14 mounting holes (20mm interval) can be used to fix the stationary plate. In this way, distance between two plates can be adjusted by 20mm, 40mm, 60mm, 80mm, 100mm, 120mm, 140mm, 160mm, 180mm. To mount the stationary plate, use 4xM6 screws. 	<p>See H in Figure 2.2</p> <p>See G in Figure 2.2</p>
2.	To keep the center of gravity stable, adjust the two positions of mounting holes at the same time.	

2 FlexGripper-Clamp

2.3.4. Mounting the FlexGripper-Clamp

2.3.4. Mounting the FlexGripper-Clamp





DANGER!



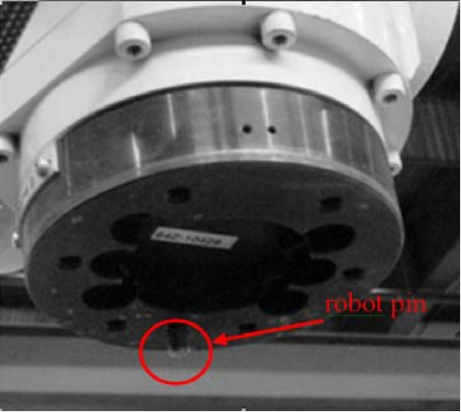

Before commencing any service work, be sure all the safety clauses have been strictly observed!

Make sure that the power is off before starting any work.

Mounting the FlexGripper-Clamp on robot

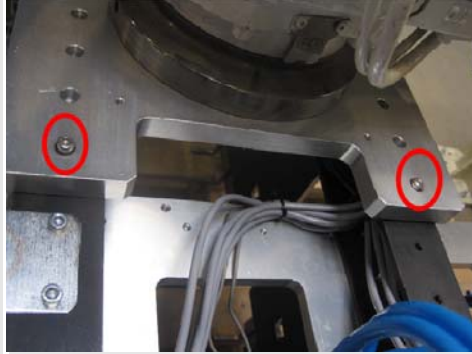
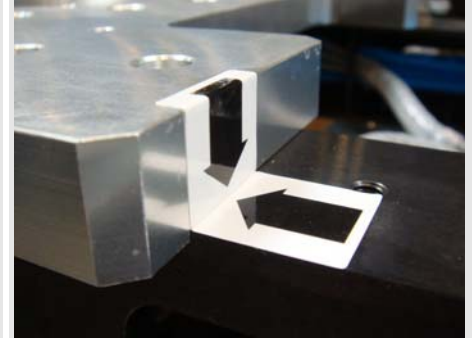
No	Action	Info/Illustration
1.	Place the wooden package so that the robot can reach it. Jog the robot wrist to the correct working height for the operators.	
2.	Insert the robot pin in the non-threaded hole on the robot wrist.(seeFigure).	 en1011031
3.	Mount the flange on the robot wrist using the 6 supplied M10 screws Moment 47 Nm (or 11x M12 Moment 80 Nm) from below upward.  NOTE! Locate the previously inserted robot pin in to the non-threaded hole in the flange plate to guarantee the FlexGripper's orientation.	 en1011015.
4.	Jog robot to find the location of the FlexGripper. Set the robot wrist to a low position (see Robot User's Guide).	

Continues on next page

No	Action	Info/Illustration
5.	<p>Mount the flange to the FlexGripper beam using the supplied 16×M6 bolts Moment 10Nm from above downward.</p> <p></p> <p>NOTE!</p> <p>The labels on the flange and the FlexGripper indicate the directions of mounting.</p> <p>Make sure the locking groove on the flange engages with the frame of the FlexGripper.</p>	 <p>en1011016</p>  <p>en1011017</p>
6.	<p>Attach the cable bracket on the flange and the cable routing to the robot wrist.</p> <p></p> <p>NOTE!</p> <p>Pass the cables through the plastic corrugated pipe which is used as the cable protection.</p>	 <p>en1011018</p>  <p>en1011019</p>

2 FlexGripper-Clamp

2.3.4. Mounting the FlexGripper-Clamp

Continued

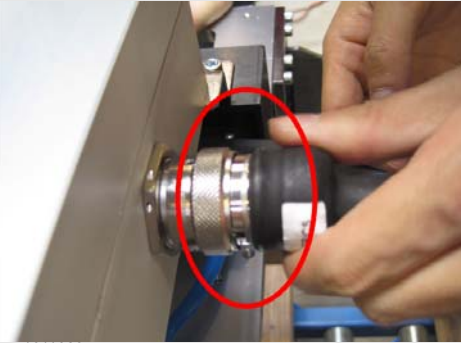
No	Action	Info/Illustration
7.	Connect the power and air cables to the manipulator wrist.	 en1011020
8.	Connect the compressed air supply cable to the valve unit and the power & signal cable to the terminal box.	 en1011023
9.	Jog the robot wrist to lift the FlexGripper package, then pull down the wooden box and separate it from the FlexGripper.	
10.	Set axis 4 to zero angle position. Manipulate the robot to check if axis 4 can rotate to the position of angle 180 clockwise and anticlockwise without tensioning of the cables and distortion of the corrugated pipe.	



NOTE!

Make sure that the standard tool kit and attached screws, washers and dowels be used during the mounting.

2.3.5. Commissioning



NOTE!

ABB recommend that air connected to the FlexGripper should be: 4-6 bar and filtered (5µm). After the electrical and pneumatic connection of the FlexGripper, test if the FlexGripper operates correctly.



NOTE!

Only 24V power is used in FlexGripper.

Short circuit protection should be implemented by a fuse in the control cabinet by the customer.



CAUTION!

Hot parts may cause burns!

Mechanical commissioning

Jog the robot to do the following actions: clamp open, clamp close, hook open, hook close, robot wrist rotation and check that the FlexGripper can operate correctly.

Pay attention to the following:

- The operation speed and smoothness. If the open and close time of the FlexGripper-Clamp is more than 0.6 s, adjust the throttle valves of the pneumatic cylinders until the operation time is less than 0.6 s.
- Check if the clamping force is suitable to handle the products, adjusting the compressed air pressure until the desired force is reached. The clamping force standard should be the force that the product can be steadily gripped and lifted only by two plates without inserting the hook.
- Check if any interference exists between cables or robot components.

Rapid routines for 1-zone gripper

Routines	Description
PFPSInitInterrupt()	This routine is called to initialize the interrupt program. According to your using of the sensors, Please modify this routine. Totally two sensors are installed on the 1-zone FlexGripper-Clamp by default.
PFPS_MainEntry()	This routine is the main entry of the 'Test run' process. It can not be renamed, modified or deleted.
PFPSClampCylinder()	This routine is called when the moving plate is set to be open or close.
PFPSHookCylinder()	This routine is called when the hook is open or close.
PFPS_PickUpBox()	This routine is called when the robot goes to pick up boxes.
PFPS_PlaceDownBox()	This routine is called when the robot goes to place down boxes.
exePickPlace()	This routine is called when the robot goes to pick up and place down boxes. The two routines 'PFPS_PickUpBox()' and 'PFPS_PlaceDownBox()' are called during the process.

Continues on next page

2 FlexGripper-Clamp

2.3.5. Commissioning

Continued



NOTE!

The clamp is open, when 'DO10_02_ClampCylinder1_Close' is set to be '0' and 'DO10_01_ClampCylinder1_Open' is set to be '1'. The clamp is close, when 'DO10_02_ClampCylinder1_Close' is set to be '1' and 'DO10_01_ClampCylinder1_Open' is set to be '0'.

PFPSClampCylinder

```
PROC PFPSClampCylinder
```

```
IF Present (Open) THEN
```

```
    SetDO DO10_02_ClampCylinder1_Close,0;
```

```
    SetDO DO10_01_ClampCylinder1_Open,1;
```

```
    WaitDI DI10_01_ClampCylinder1_Opened,1;
```

```
ENDIF      IF Present (Close) THEN
```

```
    SetDO DO10_01_ClampCylinder1_Open,0;
```

```
    SetDO DO10_02_ClampCylinder1_Close,1;
```

```
    WaitDI DI10_02_ClampCylinder1_Closed,1;
```

```
ENDIF
```

```
ENDPROC
```



NOTE!

The hook is open, when 'DO10_06_HookCylinder1_Close' is set to be '0' and 'DO10_05_HookCylinder1_Open' is set to be '1'. The hook is close, when 'DO10_06_HookCylinder1_Close' is set to be '1' and 'DO10_05_HookCylinder1_Open' is set to be '0'.

PFPSHookCylinder()

```
PROC PFPSHookCylinder()
```

```
IF Present (Close) THEN
```

```
    SetDO DO10_05_HookCylinder1_Open,0;
```

```
    SetDO DO10_06_HookCylinder1_Close,1;
```

```
    WaitDI DI10_06_HookCylinder1_Closed, 1;
```

```
ENDIF
```

```
IF Present (Open) THEN
```

```
    SetDO DO10_06_HookCylinder1_Close,0;
```

```
    SetDO DO10_05_HookCylinder1_Open,1;
```

```
    WaitDI DI10_05_HookCylinder1_Opened, 1;
```

```
ENDIF
```

```
ENDPROC
```

Continues on next page

**NOTE!**

The target points 'pHome', 'pPick' and its offsets must be defined and taught firstly.

PFPS_PickUpBox()

```

PROC PFPS_PickUpBox()
    MoveJ pHome, v100, fine, tPFPSClampGrip\WObj:=wobj0;
    TPWrite " Robot move to pick postion! ";
    MoveL Offs(pPick,-10,0,100), v100, z20, tPFPSClampGrip\WObj:=wobj0;
    MoveL pPick, v100, fine, tPFPSClampGrip\WObj:=wobj0;
    TPWrite " Robot wait for DI signle of Part detection to 1! ";
    WaitDI DI10_09_PartDetection1,1;
    WaitDI DI10_10_PartDetection2,1;
    IWatch itClampPartDectM1;
    GripLoad PFPSLoadFull;
    TPWrite " Robot start to pick up box! ";
    PFPSClampCylinder \Close;
    IWatch itClampM1;
    PFPSHookCylinder \Close;
    bPartPicked:=TRUE;
    WaitTime\InPos, 0.2;
    TPWrite " Robot finish to pick up box! ";
    MoveL Offs(pPick,0,0,50), v50, z10, tPFPSClampGrip\WObj:=wobj0;
    TPWrite " Robot move to home postion! ";
    MoveJ pHome, v100, fine, tPFPSClampGrip\WObj:=wobj0;
ENDPROC

```

2 FlexGripper-Clamp

2.3.5. Commissioning

Continued



NOTE!

The target points 'pHome', 'pPlace' and its offsets must be defined and taught firstly.

PFPS_PlaceDownBox()

```
PROC PFPS_PlaceDownBox()
    TPWrite " Robot move to place postion! ";
    MoveL Offs(pPlace,-10,0,700), v500, z20, tPFPSClampGrip\WObj:=wobj0;
    MoveL Offs(pPlace,-10,0,30), v500, z20, tPFPSClampGrip\WObj:=wobj0;
    PFPSHookCylinder \Open;
    MoveL pPlace, v50, fine, tPFPSClampGrip\WObj:=wobj0;
    TPWrite " Robot start to place down box! ";
    ISleep itClampPartDectM1;
    ISleep itClampPartDectM2;
    ISleep itClampM1;
    PFPSClampCylinder \Open;
    bPartPicked:=FALSE;
    WaitTime\InPos, 0.2;
    TPWrite " Robot finish to place box! ";
    MoveL Offs(pPlace,0,0,50), v100, z50, tPFPSClampGrip\WObj:=wobj0;
    TPWrite " Robot move to home postion! ";
    MoveJ pHome, v100, fine, tPFPSClampGrip\WObj:=wobj0;
ENDPROC
```

Rapid routines for 2-zone gripper

Routines	Description
PFPSInitInterrupt()	This routine is called to initialize the interrupt program. According to your using of the sensors, Please modify this routine. Totally two sensors are installed on the 1-zone FlexGripper-Clamp by default.
PFPS_MainEntry()	This routine is the main entry of the 'Test run' process. It can not be renamed, modified or deleted.
PFPSClampCylinder()	This routine is called when the two moving plates are set to be open or close.
PFPSClampCylinder1()	This routine is called when the moving plate 1 is set to be open or close.
PFPSClampCylinder2()	This routine is called when the moving plate 2 is set to be open or close.
PFPSHookCylinder()	This routine is called when the two hooks are open or close.
PFPSHookCylinder1()	This routine is called when the hook 1 is open or close.
PFPSHookCylinder2()	This routine is called when the hook 2 is open or close.
PFPS_PickUpBox()	This routine is called when the robot goes to pick up boxes.

Continues on next page

Continued

Routines	Description
PFPS_PlaceDownBox()	This routine is called when the robot goes to place down boxes.
exePickPlace()	This routine is called when the robot goes to pick up and place down boxes. The two routines 'PFPS_PickUpBox()' and 'PFPS_PlaceDownBox()' are called during the process.

PFPSClampCylinder

```
PROC PFPSClampCylinder
  IF Present (Open) THEN
    SetDO DO10_02_ClampCylinder1_Close,0;
    SetDO DO10_04_ClampCylinder2_Close,0;
    SetDO DO10_01_ClampCylinder1_Open,1;
    SetDO DO10_03_ClampCylinder2_Open,1;
    WaitDI DI10_01_ClampCylinder1_Opened,1;
    WaitDI DI10_03_ClampCylinder2_Opened,1;
  ENDIF
  IF Present (Close) THEN
    SetDO DO10_01_ClampCylinder1_Open,0;
    SetDO DO10_03_ClampCylinder2_Open,0;
    SetDO DO10_02_ClampCylinder1_Close,1;
    SetDO DO10_04_ClampCylinder2_Close,1;
    WaitDI DI10_02_ClampCylinder1_Closed,1;
    WaitDI DI10_04_ClampCylinder2_Closed,1;
  ENDIF
ENDPROC
```

Continues on next page

2 FlexGripper-Clamp

2.3.5. Commissioning

Continued

PFPSHookCylinder()

```
PROC PFPSHookCylinder()
  IF Present (Open) THEN
    SetDO DO10_06_HookCylinder1_Close,0;
    SetDO DO10_05_HookCylinder1_Open,1;
    SetDO DO10_08_HookCylinder2_Close,0;
    SetDO DO10_07_HookCylinder2_Open,1;
    WaitDI DI10_05_HookCylinder1_Opened, 1;
    WaitDI DI10_07_HookCylinder2_Opened, 1;
  ENDIF
  IF Present (Close) THEN
    SetDO DO10_05_HookCylinder1_Open,0;
    SetDO DO10_06_HookCylinder1_Close,1;
    SetDO DO10_07_HookCylinder2_Open,0;
    SetDO DO10_08_HookCylinder2_Close,1;
    WaitDI DI10_06_HookCylinder1_Closed, 1;
    WaitDI DI10_08_HookCylinder2_Closed, 1;
  ENDIF
ENDPROC
```

Continues on next page



NOTE!

The target points 'pHome', 'pPick' and its offsets must be defined and taught firstly.

PFPS_PickUpBox()

```
PROC PFPS_PickUpBox()
    MoveJ pHome, v100, fine, tPFPSClampGrip\WObj:=wobj0;
    TPWrite " Robot move to pick postion! ";
    MoveL Offs(pPick,-10,0,100), v100, z20, tPFPSClampGrip\WObj:=wobj0;
    MoveL pPick, v100, fine, tPFPSClampGrip\WObj:=wobj0;
    TPWrite " Robot wait for DI single of Part detection to 1! ";
    WaitDI DI10_09_PartDetection1,1;    WaitDI DI10_10_PartDetection2,1;
    IWatch itClampPartDectM1;
    GripLoad PFPSLoadFull;
    TPWrite " Robot start to pick up box! ";
    PFPSClampCylinder \Close;
    IWatch itClampM1;
    PFPSHookCylinder \Close;
    bPartPicked:=TRUE;
    WaitTime\InPos, 0.2;
    TPWrite " Robot finish to pick up box! ";
    MoveL Offs(pPick,0,0,50), v50, z10, tPFPSClampGrip\WObj:=wobj0;
    TPWrite " Robot move to home postion! ";
    MoveJ pHome, v100, fine, tPFPSClampGrip\WObj:=wobj0;
ENDPROC
```

2 FlexGripper-Clamp

2.3.5. Commissioning

Continued



NOTE!

The target points 'pHome', 'pPlace' and its offsets must be defined and taught firstly.

PFPS_PlaceDownBox()

```
PROC PFPS_PlaceDownBox()
    TPWrite " Robot move to place postion! ";
    MoveL Offs(pPlace,-10,0,700), v500, z20, tPFPSClampGrip\WObj:=wobj0;
        MoveL Offs(pPlace,-10,0,30), v500, z20, tPFPSClampGrip\WObj:=wobj0;
    PFPSHookCylinder \Open;
    MoveL pPlace, v50, fine, tPFPSClampGrip\WObj:=wobj0;
    TPWrite " Robot start to place down box! ";
    ISleep itClampPartDectM1;
    ISleep itClampPartDectM2;
    ISleep itClampM1;
    PFPSClampCylinder \Open;
    bPartPicked:=FALSE;
    WaitTime\InPos, 0.2;
    TPWrite " Robot finish to place box! ";
    MoveL Offs(pPlace,0,0,50), v100, z50, tPFPSClampGrip\WObj:=wobj0;
    TPWrite " Robot move to home postion! ";
    MoveJ pHome, v100, fine, tPFPSClampGrip\WObj:=wobj0;
ENDPROC
```

Continues on next page

Reference Rapid codes for 2-zone FlexGripper

MODULE MainModule

CONST robtarget pPick:=[[2094.58,-1118.54,1240.28],[6.7435E-07,0.64016,-0.768242,-1.6648E-06],[-1,0,-2,0],[9E+09,9E+09,9E+09,9E+09,9E+09,9E+09]];

PERS tooldata

tPFPSClampGrip:=[TRUE,[[0,0,439],[1,0,0,0]],[45,[0,0,200],[1,0,0,0],0,0,4.097]];

PERS Loaddata PFPSLoadFull:=[40,[0,0,-150],[1,0,0,0],2,4,7];

PERS Loaddata PFPSLoadEmpty:=[0.001,[0,0,0.001],[1,0,0,0],0,0,0];

PERS num cycletime:=3.111;

PERS num pace:=0;

PROC main()

var clock MyClock;

MoveJ pPick, vmax, fine,tPFPSClampGrip\WObj:=wobj0;

ConfJ \off;

confl \off;

pace:=0;clkreset MyClock;

clkstart MyClock;

for i from 1 to 5 do

PFPSClampCylinder \Close;

PFPSHookCylinder \Close;

GripLoad PFPSLoadFull;

MoveL Offs(pPick,0,0,400),vmax,z200, tPFPSClampGrip\WObj:=wobj0;

MoveL Offs(pPick,0,2000,400), vmax, z200, tPFPSClampGrip\WObj:=wobj0;

MoveL Offs(pPick,0,2000,100), vmax, fine, tPFPSClampGrip\WObj:=wobj0;

PFPSHookCylinder \Open;

MoveL Offs(pPick,0,2000,0), v1500, fine, tPFPSClampGrip\WObj:=wobj0;

PFPSClampCylinder \Open;GripLoad PFPSLoadEmpty;

!Gripper start to back!

MoveL Offs(pPick,0,2000,400), vmax, z200, tPFPSClampGrip\WObj:=wobj0;

MoveL Offs(pPick,0,0,400),vmax,z200, tPFPSClampGrip\WObj:=wobj0;

MoveL pPick,vmax,z200, tPFPSClampGrip\WObj:=wobj0;

endfor

waituntil\inpos,true;

clkStop MyClock;

cycletime:=clkRead(MyClock)/5;

pace:=3600/cycletime;

ENDPROC

PROC PFPSClampCylinder(\switch Open | switch Close)

IF Present (Open) THEN

2 FlexGripper-Clamp

2.3.5. Commissioning

Continued

```
        SetDO DO10_02_ClampCylinder1_Close,0;
        SetDO DO10_01_ClampCylinder1_Open,1;
        WaitDI DI10_01_ClampCylinder1_Opened,1;
    ENDIF
    IF Present (Close) THEN
        SetDO DO10_01_ClampCylinder1_Open,0;
        SetDO DO10_02_ClampCylinder1_Close,1;
        WaitDI DI10_02_ClampCylinder1_Closed,1;
    ENDIF
ENDPROC
PROC PFPSHookCylinder(\switch Open | switch Close)
    IF Present (Close) THEN
        SetDO DO10_05_HookCylinder1_Open,0;
        SetDO DO10_06_HookCylinder1_Close,1;
        WaitDI DI10_06_HookCylinder1_Closed,1;
    ENDIF
    IF Present (Open) THEN
        SetDO DO10_06_HookCylinder1_Close,0;
        SetDO DO10_05_HookCylinder1_Open,1;
        WaitDI DI10_05_HookCylinder1_Opened,1;
    ENDIF
ENDPROC
ENDMODULE
```

Continues on next page

Reference Rapid codes for 2-zone FlexGripper

MODULE MainModule

CONST robtarg pPick:=[[2094.58,-1118.54,1240.28],[6.7435E-07,0.64016,-0.768242,-1.6648E-06],[-1,0,-2,0],[9E+09,9E+09,9E+09,9E+09,9E+09,9E+09]];

PERS tooldata

tPFPSClampGrip:=[TRUE,[[0,0,539],[1,0,0,0]],[80,[0,0,200],[1,0,0,0],0,0,4.097]];

PERS Loaddata PFPSLoadFull:=[60,[0,0,-150],[1,0,0,0],3.7,7.7,15];

PERS Loaddata PFPSLoadEmpty:=[0.001,[0,0,0.001],[1,0,0,0],0,0,0];

PERS num cycletime:=3.111;

PERS num pace:=0;

PROC main()

var clock MyClock;

MoveJ pPick, vmax, fine,tPFPSClampGrip\WObj:=wobj0;

ConfJ \off;

confl \off;

pace:=0;

clkreset MyClock;

clkstart MyClock;

for i from 1 to 5 do

PFPSClampCylinder \Close;

PFPSHookCylinder \Close;

GripLoad PFPSLoadFull;

MoveL Offs(pPick,0,0,400),vmax,z200, tPFPSClampGrip\WObj:=wobj0;

MoveL Offs(pPick,0,2000,400), vmax, z200, tPFPSClampGrip\WObj:=wobj0;

MoveL Offs(pPick,0,2000,100), vmax, fine, tPFPSClampGrip\WObj:=wobj0;

PFPSHookCylinder \Open;

MoveL Offs(pPick,0,2000,0), v1500, fine, tPFPSClampGrip\WObj:=wobj0;

PFPSClampCylinder \Open;

GripLoad PFPSLoadEmpty;

!Gripper start to back!

MoveL Offs(pPick,0,2000,400), vmax, z200, tPFPSClampGrip\WObj:=wobj0;

MoveL Offs(pPick,0,0,400),vmax,z200, tPFPSClampGrip\WObj:=wobj0;

MoveL pPick,vmax,z200, tPFPSClampGrip\WObj:=wobj0;

endfor

waituntil\inpos,true;

clkStop MyClock;

cycletime:=clkRead(MyClock)/5;

pace:=3600/cycletime;

ENDPROC

2 FlexGripper-Clamp

2.3.5. Commissioning

Continued

```
PROC PFPSClampCylinder(\switch Open | switch Close)
  IF Present (Open) THEN
    SetDO DO10_02_ClampCylinder1_Close,0;
    SetDO DO10_04_ClampCylinder2_Close,0;
    SetDO DO10_01_ClampCylinder1_Open,1;
    SetDO DO10_03_ClampCylinder2_Open,1;
    WaitDI DI10_01_ClampCylinder1_Opened,1;
    WaitDI DI10_03_ClampCylinder2_Opened,1;
    ENDIF
  IF Present (Close) THEN
    SetDO DO10_01_ClampCylinder1_Open,0;
    SetDO DO10_03_ClampCylinder2_Open,0;
    SetDO DO10_02_ClampCylinder1_Close,1;
    SetDO DO10_04_ClampCylinder2_Close,1;
    WaitDI DI10_02_ClampCylinder1_Closed,1;
    WaitDI DI10_04_ClampCylinder2_Closed,1;
    ENDIF
ENDPROC

PROC PFPSHookCylinder(\switch Open | switch Close)
  IF Present (Open) THEN
    SetDO DO10_06_HookCylinder1_Close,0;
    SetDO DO10_05_HookCylinder1_Open,1;
    SetDO DO10_08_HookCylinder2_Close,0;
    SetDO DO10_07_HookCylinder2_Open,1;
    WaitDI DI10_05_HookCylinder1_Opened, 1;
    WaitDI DI10_07_HookCylinder2_Opened, 1;
    ENDIF
  IF Present (Close) THEN
    SetDO DO10_05_HookCylinder1_Open,0;
    SetDO DO10_06_HookCylinder1_Close,1;
    SetDO DO10_07_HookCylinder2_Open,0;
    SetDO DO10_08_HookCylinder2_Close,1;
    WaitDI DI10_06_HookCylinder1_Closed, 1;
    WaitDI DI10_08_HookCylinder2_Closed, 1;
    ENDIF
ENDPROC
ENDMODULE
```

Continues on next page

Continued

Software commissioning

For detailed software commissioning procedure, see *FlexGripper-Clamp (FlexGripper-Clamp 1) function test on page 104* and *FlexGripper-Clamp (FlexGripper-Clamp 2) function test on page 105*.

2 FlexGripper-Clamp

2.4.1. General

2.4 Maintenance

2.4.1. General

This chapter details all maintenance activities recommended for the FlexGripper-Clamp. For the torque values needed during maintenance, please see *Recommended standard tightening torque on page 30*.



WARNING!

During maintenance, disconnect the mains voltage before any work is started. Even if the voltage is switched off there still remains a safety risk. Pneumatic and electric connections should be disconnected before performing any maintenance activity on the FlexGripper

Safety information

Before any service work is started, it is extremely important that all safety information is read and followed! There are general safety aspects that must be read through, as well as more specific safety information that describe danger and safety risks when performing the procedures. Read the chapter *Safety on page 7* before performing any service work.

2.4.2. Regular Inspection of FlexGripper-Clamp

Perform general visual system inspection regularly before starting an operation. Parts that need to be visually inspected with a more regular interval (less than a half year and so on) are:

Type	Action
Fastener	Check that the fastener is not lose.
Rubber pad	Check the wear extent of the rubber pads.
Cable protection	Check the wear extent of the cable protection.
Pneumatic accessory	Regularly check that the piston rods of the cylinders are free from dust particles and that there is no air leakage. Ensure all the Valve terminal connectors are tightened properly and that there is no air leakage.
Linear guide	Regularly check that the guide rail and slide block are free from dust particles.
Clamp plate	Check for any distortion in the plates.
Hook distortion	Check for any distortion in the hooks.
Stationary plate	Check the wear extent of the stationary plate.
Pressure regulator	Check the water volume of the filter in the pressure regulator.

Parts that need to be disassembled and inspected with a relatively longer interval (one year and so on) are:

Type	Action
Joint pin	Disassemble all the joint pins in the FlexGripper-Clamp to check their wear extent.

2 FlexGripper-Clamp

2.4.3. Regular replacement

2.4.3. Regular replacement

In any of the following situations, the corresponding component should be replaced:

- The hook unit/hook finger is distorted
- The corrugated pipe has worn out
- The rubber pad has worn down seriously and has affected the gripping capacity
- Pins in the FlexGripper-Clamp have worn out seriously
- The clamp plates are distorted
- Any component that no longer functions correctly
- Any component that has exceeded its lifetime

2.5 Repair

2.5.1. Instruction

This chapter details all repair activities recommended for the FlexGripper-Clamp.

Safety information

Before any service work is started, it is extremely important that all safety information is read! There are general safety aspects that must be read through, as well as more specific safety information that describes the danger and safety risks when performing specific steps in a procedure. Make sure to read through the chapter *Safety on page 7* before commencing any service work.



NOTE!

Make sure that the FlexGripper-Clamp is disconnected from the mains power supply before starting any repair work.

2 FlexGripper-Clamp

2.5.2.1. Replacing the moving plate cylinder

2.5.2. Cylinder

2.5.2.1. Replacing the moving plate cylinder

The cylinder is located as shown in the figure below.

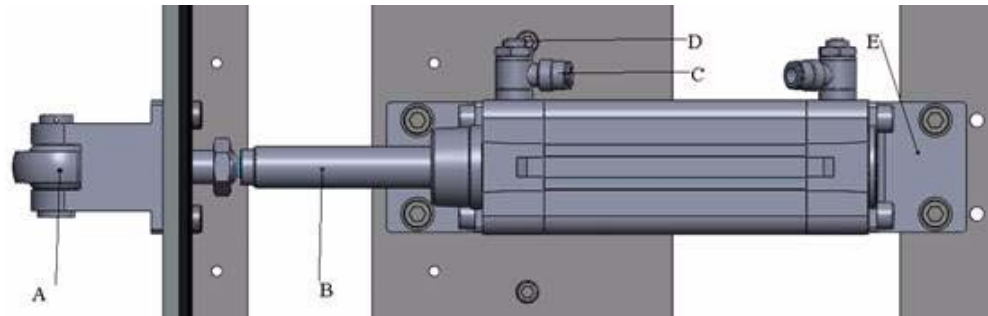

en1012001

Position	Part
A	Spherical hinge
B	Pneumatic cylinder
C	Quick connector
D	Flow valve
E	Base of pneumatic cylinder

Use this procedure to remove the cylinder.



DANGER!

Turn off all electric power and pneumatic pressure supplies to the gripper!

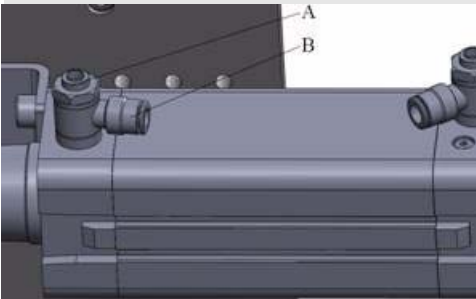
Action	Note
1. Drain the air from the cylinder.	Pull out air cable on cylinder.
2. Remove the flow control valve and joint.	 <p>en1012002 Parts: A: flow control valve, B: joint</p>

Continues on next page

Continued

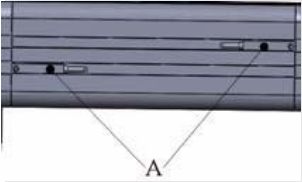
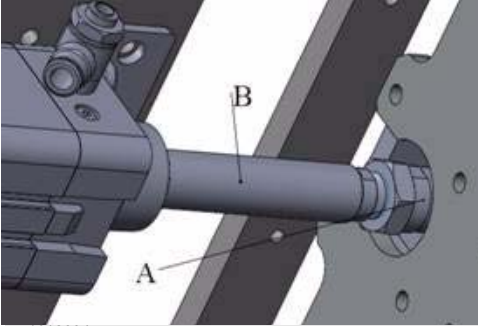
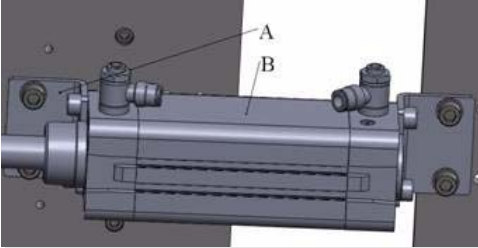
	Action	Note
3.	Remove the sensors from the cylinder.	 <p>en1012003 Parts: A: sensor</p>
4.	Remove the joint from the piston rod of the cylinder.	 <p>en1012004 Parts: A: joint, B: piston rod</p>
5.	Remove the bracket from the cylinder.	 <p>en1012005 Parts: A: bracket, B: cylinder</p>
6.	Remove the cylinder.	

2 FlexGripper-Clamp

2.5.2.2. Replacing the cylinder of hook

2.5.2.2. Replacing the cylinder of hook

The cylinder is located as shown in the figure below.

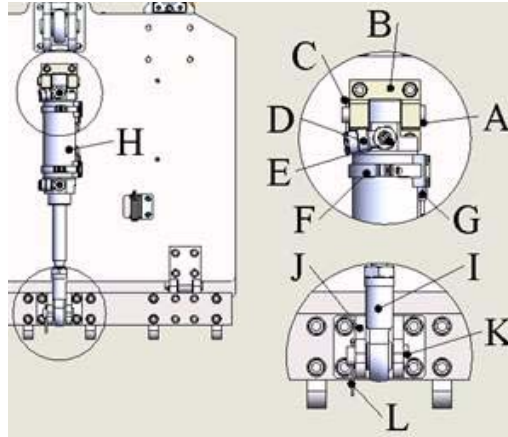

en1012006

Position	Part
A	Pin1 for 40 cylinder
B	40 cylinder bracket 1
C	Split pin 1.6X32
D	Quick connector
E	Flow valve
F	Limit switch strap
G	Magnetic proximity switch
H	Pneumatic cylinder
I	Spherical hinge
J	40 cylinder bracket 2
K	Pin2 for 40 cylinder
L	Split pin 1.6X32

Continues on next page

Use this procedure to remove the cylinder.

DANGER!

Turn off all electric power and pneumatic pressure supplies to the gripper!

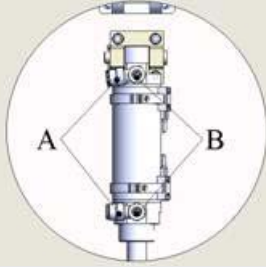
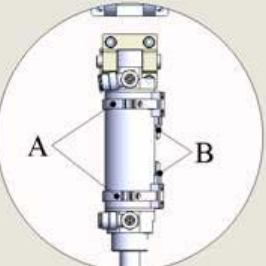
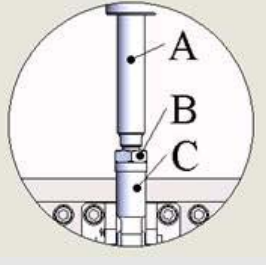

	Action	Note
1.	Drain the air from the cylinder.	Disconnect air cable on the cylinder.
2.	Remove the flow valve and the quick connector.	 <p>en1012007 Parts: A: Quick connector, B: Flow valve</p>
3.	Remove the magnetic proximity switch and the limit switch strap.	 <p>en1012008 Parts: A: limit switch strap, B: magnetic proximity switch</p>
4.	Loosen the nut on the pneumatic cylinder.	 <p>en1012009 Parts: A: Piston rod, B: Nut, C: spherical hinge</p>

2 FlexGripper-Clamp

2.5.2.2. Replacing the cylinder of hook

Continued

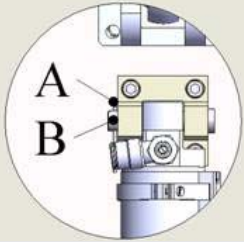
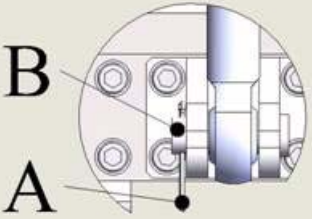
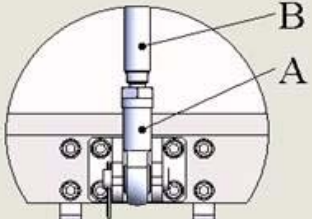
	Action	Note
5.	Remove the split pin and then remove pin1 for 40cylinder.	 <p>en1012010 Parts: A: Split pin, B: Pin1 for 40cylinder</p>
6.	Remove the split pin and then remove pin2 for 40cylinder.	 <p>en1012011 Parts: A: Split pin, B: Pin2 for 40cylinder</p>
7.	Remove the spherical hinge.	 <p>en1012012 Parts: A: Spherical hinge, B: Piston rod</p>
8.	Remove the cylinder.	

2.5.3. Magnetic proximity switch

The magnetic proximity switch is located as shown in the figure below.

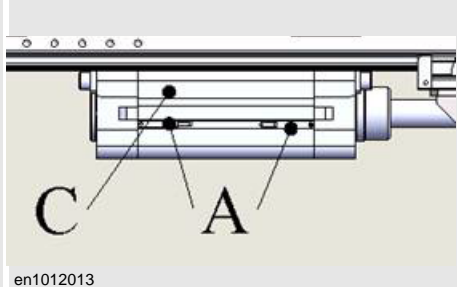
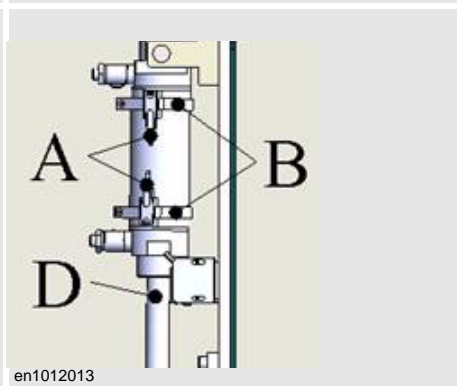
Position 1	 <p>en1012013</p>
Position 2	 <p>en1012013</p>
A	Magnetic proximity switch
B	Limit switch strap
C	Pneumatic cylinder
D	Pneumatic cylinder

Position 1

Use this procedure to remove the magnetic proximity switch.



DANGER!

Turn off all electric power, pneumatic pressure supplies to the gripper!

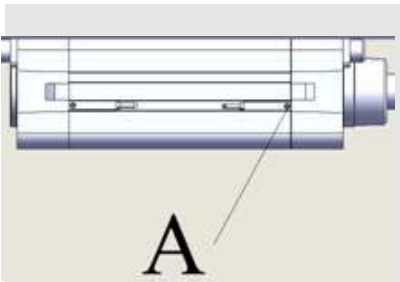
Action	Note
1. Loosen the small bolt and pull out the magnetic proximity switch.	 <p>en1012015 Parts: A: Small bolt</p>
2. Open the electrical box and remove the cable.	See circuit diagram for details.
3. Remove the magnetic proximity switch.	

Continues on next page

2 FlexGripper-Clamp

2.5.3. Magnetic proximity switch

Continued

Position 2

Use this procedure to remove the magnetic proximity switch.

DANGER!

Turn off all electric power, pneumatic pressure supplies to the gripper!

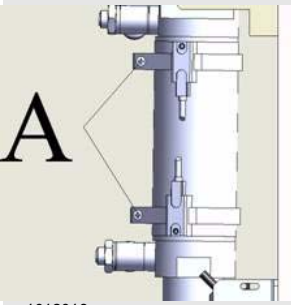

Action	Note
1. Loosen the small bolt and pull out the magnetic proximity switch from the limit switch strap.	 <p>en1012016 Parts: A: Small bolt</p>
2. Open the electrical box and remove the cable.	See circuit diagram for details.
3. Remove the magnetic proximity switch.	

2.5.4. Sensors

The sensors are located as shown in the figure below.

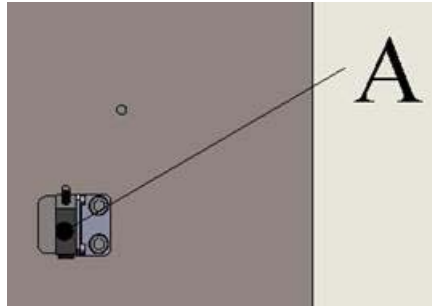

en1012017

Position	Part
A	Sensor (there are 2 sensors on gripper)

Use this procedure to remove the sensors.



DANGER!

Turn off all electric power, pneumatic pressure supplies to the gripper!

Action	Note
1. Loosen the small bolt.	<p>en1012018 Parts: A: Small bolt</p>
2. Open the electrical box and remove the cable.	See circuit diagram for details.
3. Remove the sensor.	

2 FlexGripper-Clamp

2.5.5. Solenoid valve

2.5.5. Solenoid valve

The solenoid valves are located as shown in the figure below.

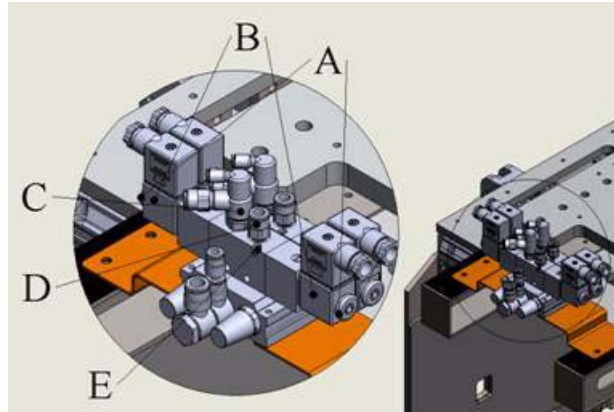

en1012019

Position	Part
A	Nut
B	Power supply
C	One way valve
D	Quick connector
E	Bolt

Use this procedure to remove the solenoid valve.



DANGER!

Turn off all electric power and pneumatic pressure supplies to the gripper!

	Action	Note
1.	Drain the air from the cylinder.	Disconnect the air cable.
2.	Remove the one way valve.	
3.	Remove the quick connector.	
4.	Loosen the nut.	
5.	Remove the power supply.	
6.	Loosen the bolt.	
7.	Remove the solenoid valve.	

2.5.6. Dress cable

The dress cable is located as shown in the figure below.

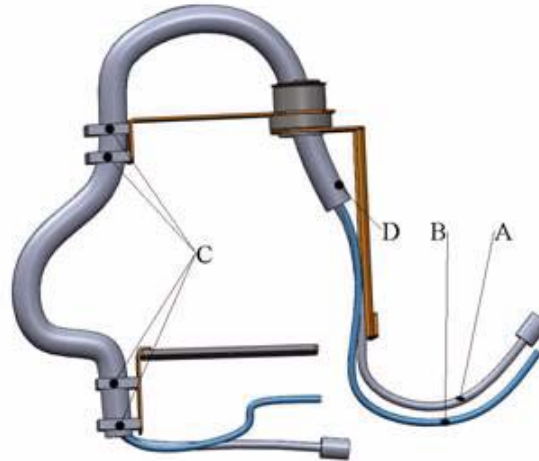

en1012020

Position	Part
A	Electrical cable
B	Main compressed air hose
C	Corrugated pipe clip
D	Dress cable

Use this procedure to remove the dress cable magnetic proximity switch.



DANGER!

Turn off all electric power and pneumatic pressure supplies to the gripper!

	Action	Note
1.	Drain the air from the cylinder.	Disconnect the air cable.
2.	Pull out the main compressed air hose from the two sidequick connectors.	
3.	Pull out the electrical cable from both side (one side-Gripper electricalbox,theothersideRobotaxis6).	
4.	Open the corrugated pipe clip.	
5.	Remove the dress cable.	

2 FlexGripper-Clamp

2.6.1. Start-up failures

2.6 Trouble shooting

2.6.1. Start-up failures

Consequences

Problem starting the system

Symptoms and causes

- LEDs not lit on the sensors.
- Air hose hangs loosely on the gripper.

Recommended actions

	Action	Info/illustration
1.	Make sure the robot system has started up and is correctly connected.	
2.	Make sure the air source is open.	
3.	Make sure the gripper cable and air hose are correctly connected to the dress cable.	
4.	Make sure the gripper cable is correctly connected to the terminal box on the gripper.	

2.6.2. Gripper not responding

Consequences

The gripper cannot be operated using the FlexPendant.

Recommended actions

	Action	Info/illustration
1.	Make sure the gripper system has started up.	
2.	Make sure the connection to the I/O board is correct.	
3.	Make sure that there is no air leakage.	

2 FlexGripper-Clamp

2.6.3. Wrong movement

2.6.3. Wrong movement

Consequences

The fault can cause severe injuries or death to personnel in the area or severe damage to the manipulator and/or surrounding equipment.

Symptoms and causes

The movement of the gripper part is not as expected during commissioning.

Recommended actions

	Action	Info/illustration
1.	Make sure the connection to the I/O board is correct.	
2.	Check the connection in the terminal box.	

2.6.4. Low performance

Consequences

Clamp or hook movement is sluggish and sometimes stalls.

Symptoms and causes

- Connection error
- Low air pressure
- Excessive friction

Recommended actions

	Action	Info/illustration
1.	Make sure the electrical and air connections are correctly and firmly connected.	
2.	Make sure the air pressure is between 4 bar and 6 bar.	
3.	Make sure there is no excessive friction between moving parts (See section Mechanical noise).	

2 FlexGripper-Clamp

2.6.5. Problem jogging the gripper

2.6.5. Problem jogging the gripper

Consequences

Gripper can not reach the rotation range.

Symptoms and causes

Cable or air hose routing.

Recommended actions

	Action	Info/illustration
1.	Make sure the cable and air hose are correctly routed.	

2.6.6. Oil stains on gripper

Consequences

In some cases the oil may contaminate the workpiece.

Symptoms and causes

Too much oil for the linear guide.

Recommended actions

	Action	Info/illustration
1.	Clean up the redundant oil.	

2 FlexGripper-Clamp

2.6.7. Mechanical noise

2.6.7. Mechanical noise

Consequences

- Failing bearings cause the palletizing accuracy, and in severe cases, the workpiece may fall down uncontrolly.
- The gripper part or workpiece may fall down.

Symptoms and causes

- Loose bolts

Recommended actions

	Action	Info/illustration
1.	Determine which bearing is emitting the noise.	
2.	Make sure the bearing has sufficient lubrication.	
3.	Replace the bearing with a new one.	

	Action	Info/illustration
1.	Determine which bearing is emitting the noise.	
2.	Tighten the bolts to the recommended torque.	

2.6.8. Workpiece drop on power down

Consequences

The fault can cause severe injuries or death to personnel in the area or severe damage to the manipulator and/or surrounding equipment.

Symptoms and causes

- Faulty valve.
- Faulty air connection or air leakage.

Recommended actions

	Action	Info/illustration
1.	Determine which valve causes the workpiece to drop.	
2.	Check the air hose connection.	

2 FlexGripper-Clamp

2.6.9. Workpiece drop on air down

2.6.9. Workpiece drop on air down

Consequences

The fault can cause severe injuries or death to personnel in the area or severe damage to the manipulator and/or surrounding equipment.

Symptoms and causes

- Faulty valve or air connection.
 - Faulty air connection or air leakage.
-

Recommended actions

	Action	Info/illustration
1.	Determine which valve causes the workpiece to drop.	
2.	Check the air hose connection.	

2.6.10. No Input signal detected

Consequences

Can not run work program.

Symptoms and causes

- No signal detected in UI. LEDs not lit on the I/O board.
- Faulty connection.

Recommended actions

	Action	Info/illustration
1.	Make sure the LEDs sensors are lit and all the connections are firmly connected.	
2.	Check the connection on the I/O board.	

2 FlexGripper-Clamp

2.7.1. Introduction

2.7 Decommissioning

2.7.1. Introduction

Introduction

This section contains information to consider when taking a product, FlexGripper, out of operation. It deals with how to handle potentially dangerous components and potentially hazardous materials.

General

All used grease, oils and dead batteries must be disposed of in accordance with the current legislation of the country in which the FlexGripper units are installed. If the FlexGripper units are partially or completely disposed of, the various parts must be grouped together according to their nature (that is, all iron together and all plastic together), and disposed of accordingly. These parts must also be disposed of in accordance with the current legislation of the country in which the FlexGripper units are installed.

2.7.2. Environmental information

Hazardous material

The table specifies some of the materials in the FlexGripper and their respective use throughout the product.

Dispose of the components properly to prevent health or environmental hazards.

Material	Example application
Copper	Cables
Steel	Screws, base-frame, and so on
Cast iron/nodular iron	Hook fingers
Plastic/rubber (PVC)	Cables, connectors, and so on
Oil, grease	Linear guide
Aluminium	Flange, Moving plate

Oil and grease

Where possible, arrange for the oil and grease to be recycled. Dispose of via an authorized person/contractor in accordance with local regulations. Do not dispose of oil and grease near lakes, ponds, ditches, down drains or onto soil. Incineration must be carried out under controlled conditions in accordance with local regulations.

Also note that:

- Spills may form a film on water surfaces causing damage to organisms. Oxygen transfer could also be impaired. Spillage may penetrate the soil causing ground water contamination.

2 FlexGripper-Clamp

2.8. Ware part

2.8. Ware part

FlexGripper type	Part No.	Description
1-zone	3HAC040555-001	Move plate with rubber
2-zone	3HAC040556-001	Move plate with rubber

2 FlexGripper-Clamp

2.9. Spare parts

Continued

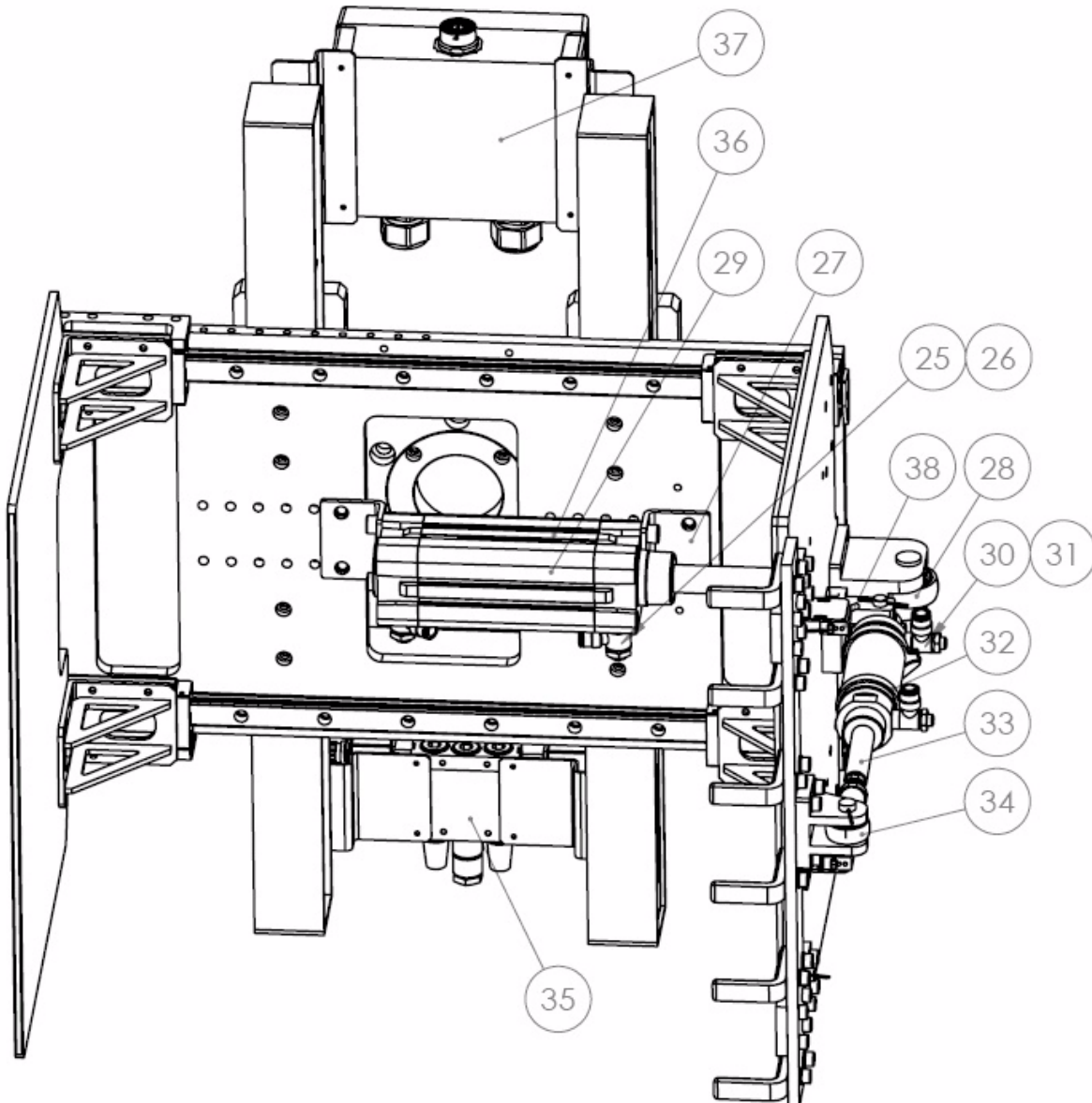

en1016001

Continues on next page

Spare parts list for 1-zone

Pos	Part No.	Description	Qty	Note / Dimension
1	3HAC040415-001	Flange plate for 460	1	Product in IRB 460
1	3HAC040417-001	Flange plate for 660	1	Product in IRB 660
2	3HAC040416-001	Shaft fitting for 460	1	Product in IRB 460
2	3HAC040418-001	Shaft fitting for 660	1	Product in IRB 660
3	3HAC038579-001	Beam machining	2	
4	3HAC040298-001	Bracket for valve	2	
5	3HAC040299-001	Bracket for box	2	
6	3HAC038580-001	Base plate	1	
7	3HAC040213-001	Restric block	2	
8	3HAC038582-001	Bracket machining	4	
10	3HAC038584-001	Stationary plate	1	
11	3HAC038591-001	Bracket for 50 cylinder	1	
12	3HAC040433-001	Pin for 50 cylinder	1	
13	3HAC038592-001	Switch Bracket	2	
14	3HAC038585-001	Stopper	4	
15	3HAC038586-001	Hook base plate	1	
16	3HAC038587-001	Hook	6	
17	3HAC040185-001	40 cylinder bracket 2	1	
18	3HAC038590-001	Hinge 2	2	
19	3HAC038589-001	Hinge pin	2	
20	3HAC038588-001	Hinge 1	2	
21	3HAC040192-001	Qin1 for 40 cylinder	1	
22	3HAC038594-001	Qin2 for 40 cylinder	1	
23	3HAC040193-001	40 cylinder bracket 1	1	
24	3HAC040432-001	Heavy load SHS-LC20 (THK)	2	
25	3HAC040791-001	Flow valve	2	
26	3HAC040792-001	Quick connector	2	
27	3HAC040793-001	Base of Pneumatic cylinder	1	
28	3HAC040794-001	Spherical hinge	1	
29	3HAC040795-001	Pneumatic cylinder	1	
30	3HAC040796-001	Flow valve	2	
31	3HAC040797-001	Quick connector	2	
32	3HAC040798-001	Limit switch strap	2	
33	3HAC040799-001	Pneumatic cylinder	1	
34	3HAC040800-001	Spherical hinge	1	

en1016001

2-zone FlexGripper

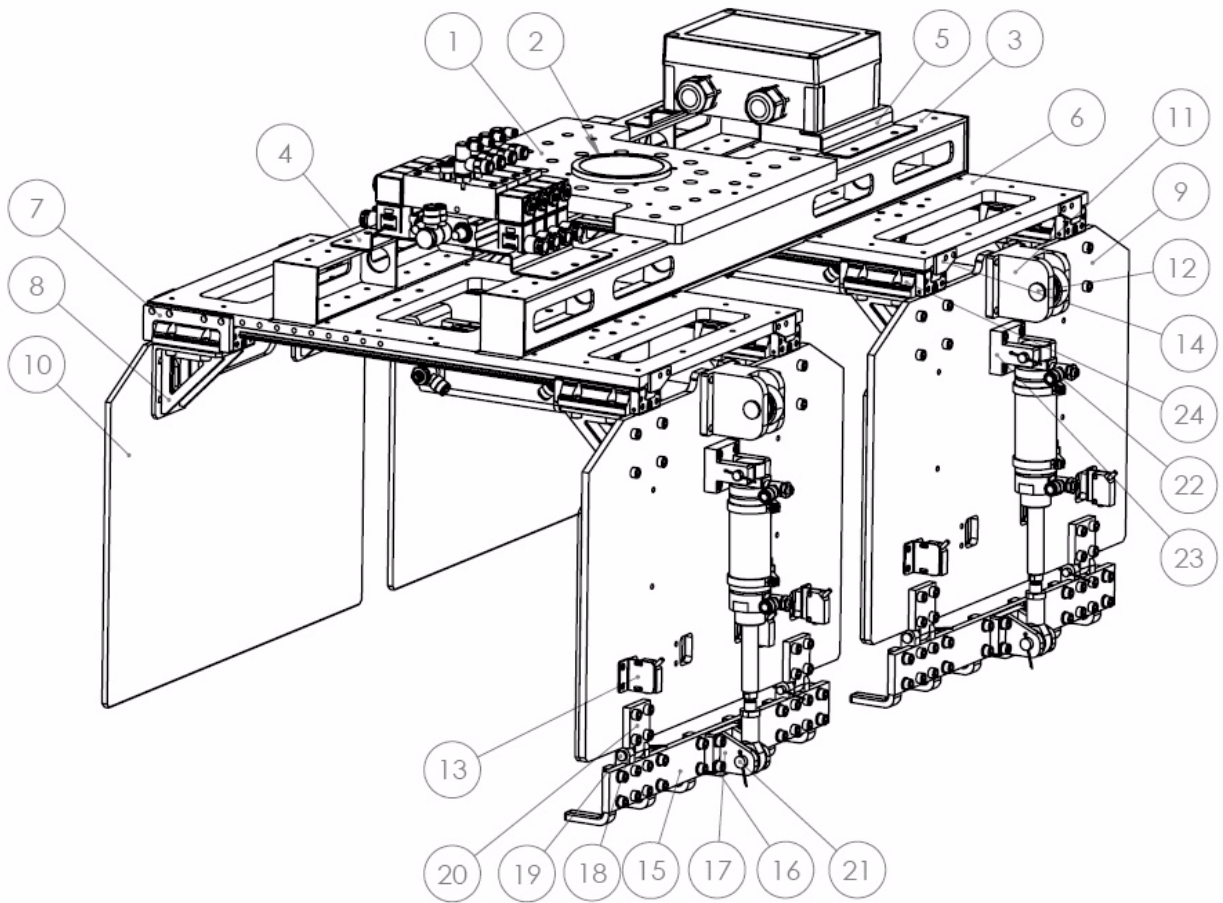

en1016001

2 FlexGripper-Clamp

2.9. Spare parts

Continued

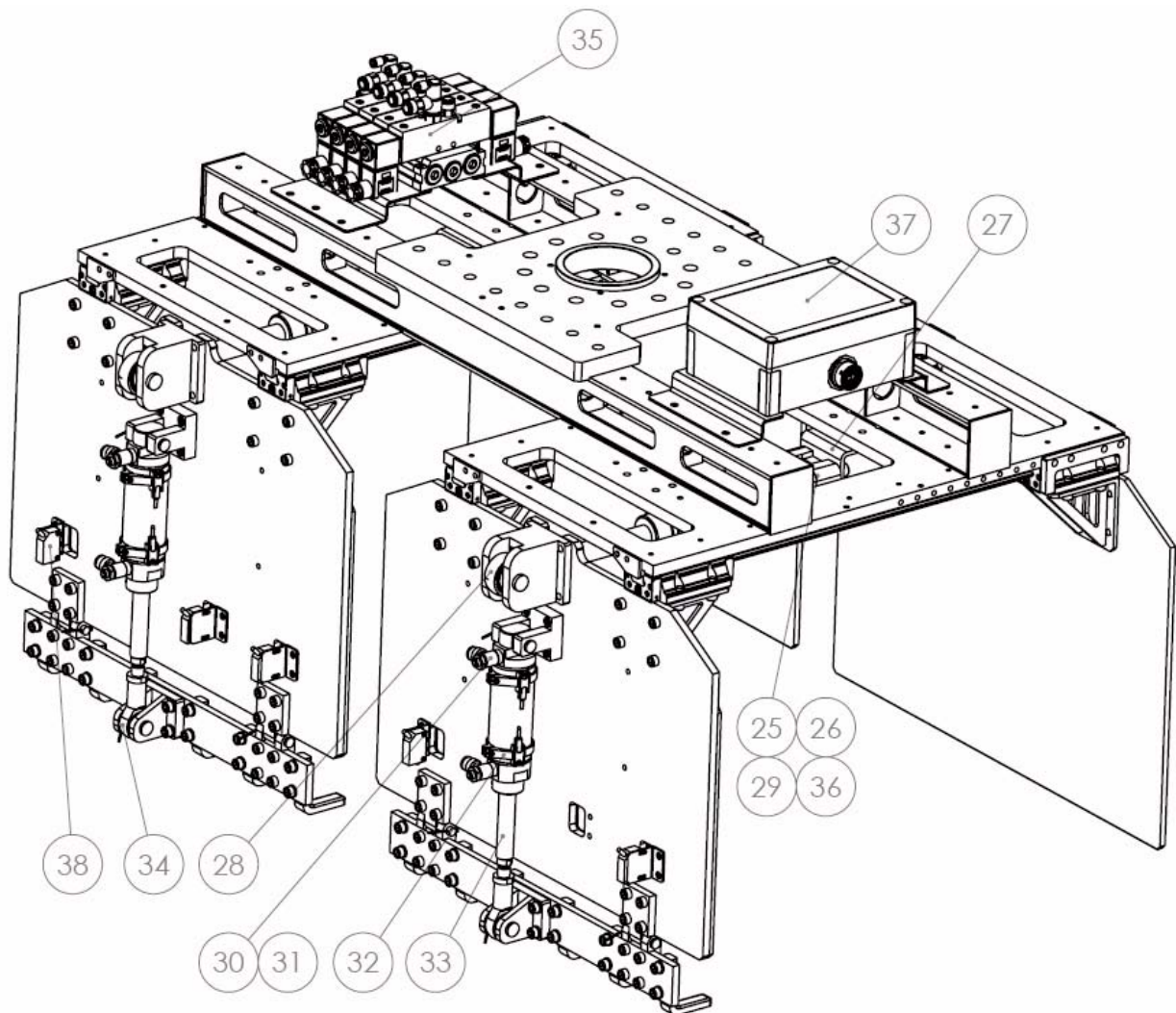

en1016001

Spare parts list for 2-zone

Pos	Part No.	Description	Qty	Note / Dimension
1	3HAC040415-001	Flange plate for 460	1	Product in IRB 460
1	3HAC040417-001	Flange plate for 660	1	Product in IRB 660
2	3HAC040416-001	Shaft fitting for 460	1	Product in IRB 460
2	3HAC040418-001	Shaft fitting for 660	1	Product in IRB 660
3	3HAC040429-001	Beam machining	2	
4	3HAC040431-001	Bracket for valve	2	
5	3HAC040299-001	Bracket for box	2	
6	3HAC038580-001	Base plate	2	
7	3HAC040213-001	Restrict block	4	
8	3HAC038582-001	Bracket machining	8	
10	3HAC040483-001	Stationary plate	2	
11	3HAC038591-001	Bracket for 50 cylinder	2	
12	3HAC040433-001	Pin for 50 cylinder	2	
13	3HAC038592-001	Switch Bracket	5	
14	3HAC038585-001	Stoper	8	
15	3HAC038586-001	hook base plate	2	
16	3HAC038587-001	Hook	12	
17	3HAC040185-001	40 cylinder bracket2	2	
18	3HAC038590-001	Hinge2	4	
19	3HAC038589-001	hinge pin	4	
20	3HAC038588-001	Hinge1	4	
21	3HAC040192-001	pin1 for 40 cylinder	2	
22	3HAC038594-001	pin2 for 40 cylinder	2	
23	3HAC040193-001	40 cylinder bracket1	2	
24	3HAC040432-001	Heavy load SHS-LC20(THK)	4	
25	3HAC040791-001	flow valve	4	
26	3HAC040792-001	quick connector	4	
27	3HAC040793-001	base of Pneumatic cylinder	2	
28	3HAC040794-001	spherical hinge	2	
29	3HAC040795-001	Pneumatic cylinder	2	
30	3HAC040796-001	flow valve	4	
31	3HAC040797-001	quick connector	4	
32	3HAC040798-001	limit switch strap	4	
33	3HAC040799-001	Pneumatic cylinder	2	
34	3HAC040800-001	spherical hinge	2	

en1016001

2.10 Circuit diagram

2.10.1. Electrical circuit

Power supply circuit

We reserve all rights in this document and in the information contained therein. Reproduction, use or disclosure to third parties without express authority is strictly forbidden. © Copyright 2003 ABB

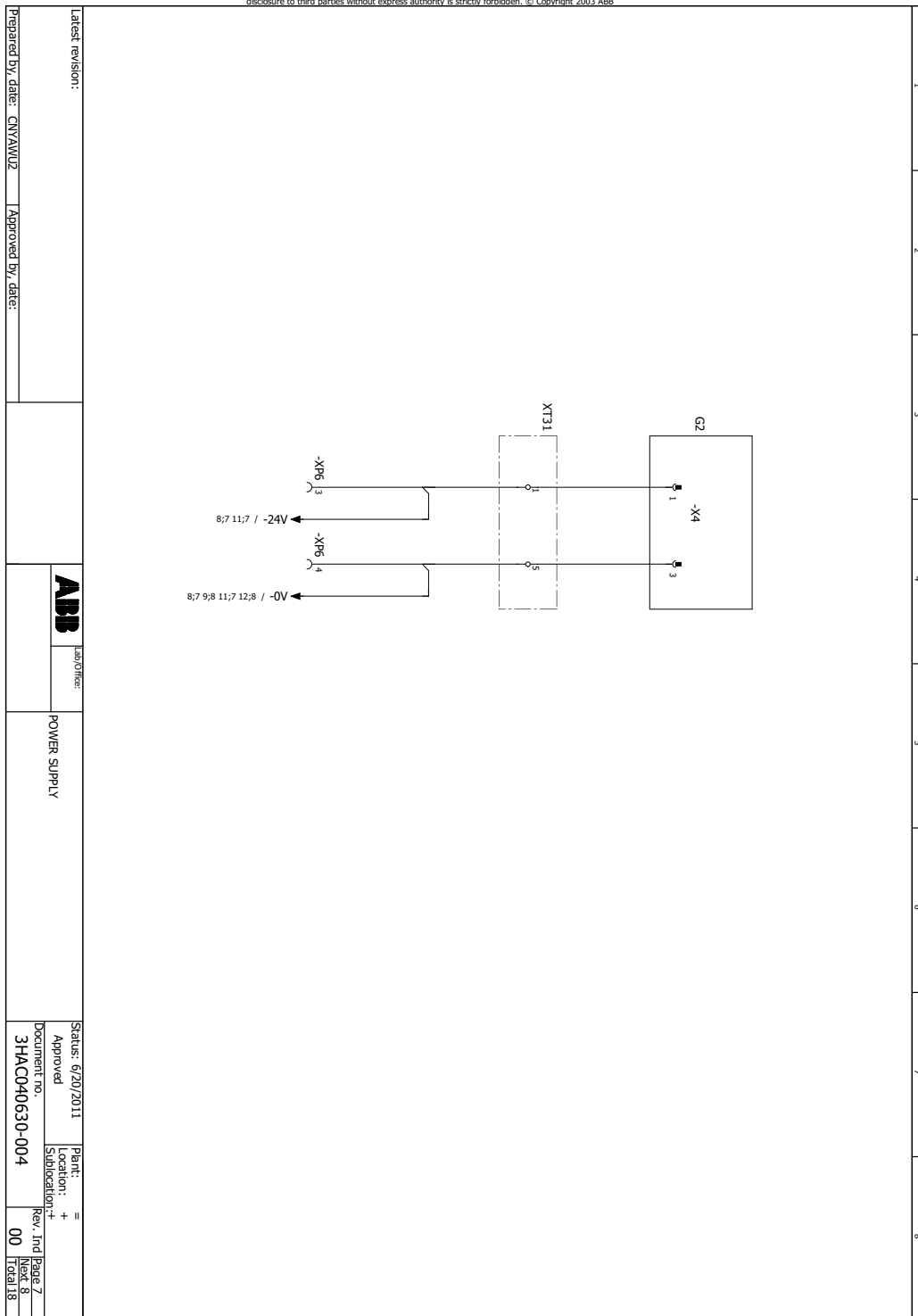

3HAC040149-003-8

Continues on next page

2 FlexGripper-Clamp

2.10.1. Electrical circuit

Continued

FlexGripper-Clamp 1 DO

We reserve all rights in this document and in the information contained therein. Reproduction, use or disclosure to third parties without express authority is strictly forbidden. © Copyright 2003 ABB

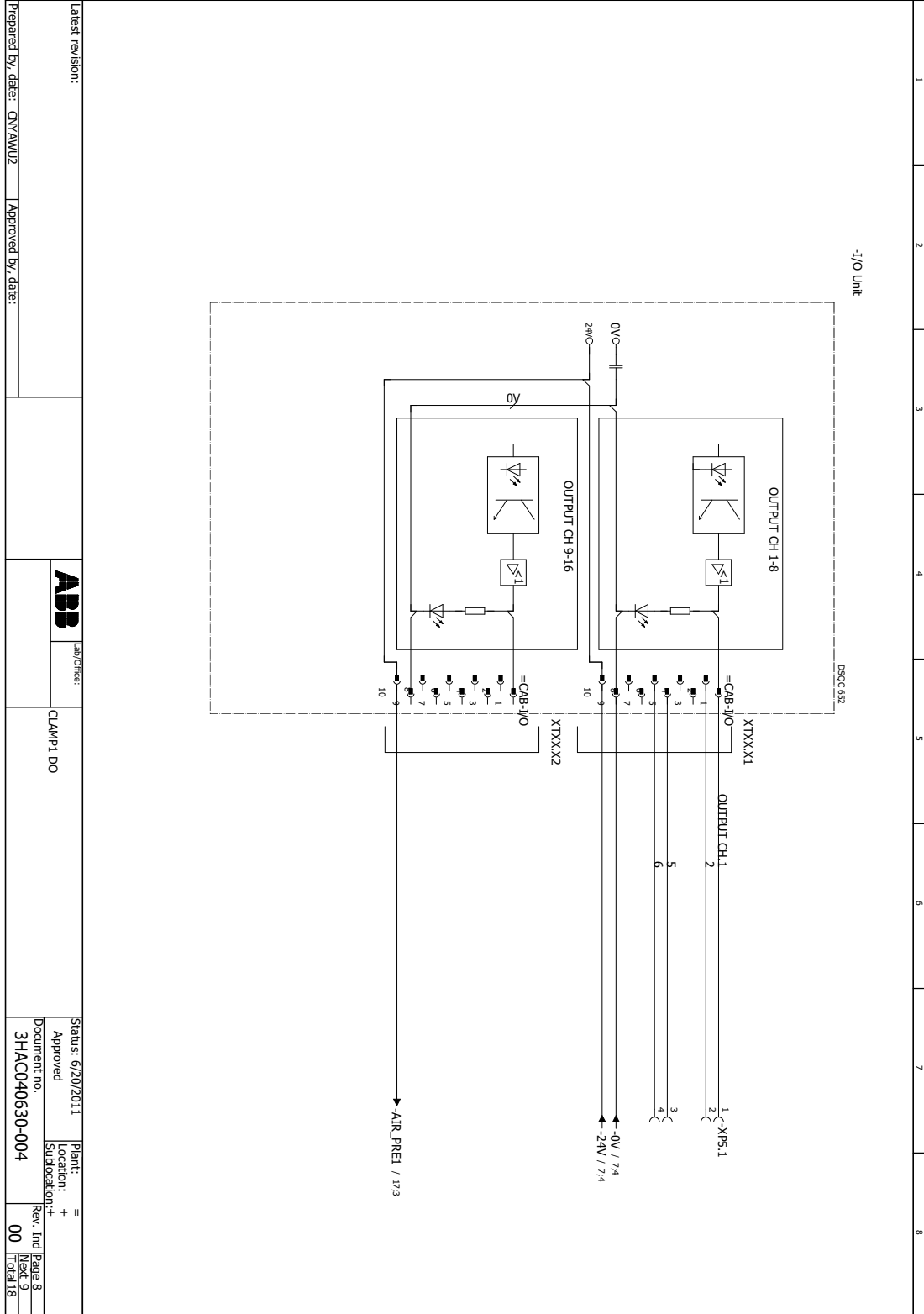

Latest revision:	
Prepared by, date: ONYAWU2	Approved by, date:
ABB Lab/Office:	
CLAMP1 DO	
Status: 6/20/2011	Part: =
Approved	Location: +
Document no. 3HAC040630-004	Sublocation: +
	Rev. 1nd
	Page 8
	Next 9
	Total 18

3HAC040149-003-8

Continues on next page

Continued

FlexGripper-Clamp 1 DI

We reserve all rights in this document and in the information contained therein. Reproduction, use or disclosure to third parties without express authority is strictly forbidden. © Copyright 2003 ABB

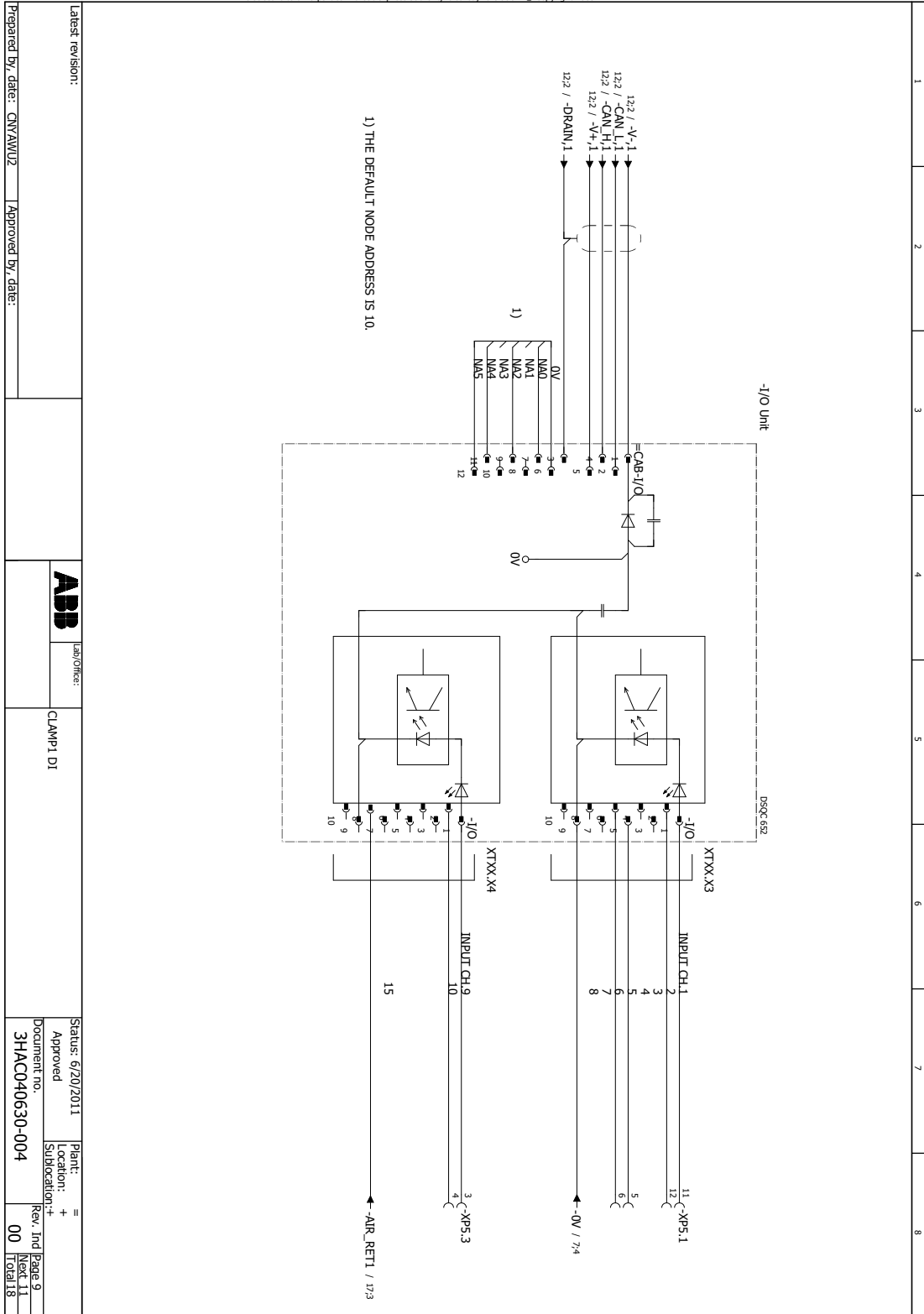

3HAC040149-003-9

Continues on next page

2 FlexGripper-Clamp

2.10.1. Electrical circuit

Continued

FlexGripper-Clamp 1 terminal connection

We reserve all rights in this document and in the information contained therein. Reproduction, use or disclosure to third parties without express authority is strictly forbidden. © Copyright 2003 ABB

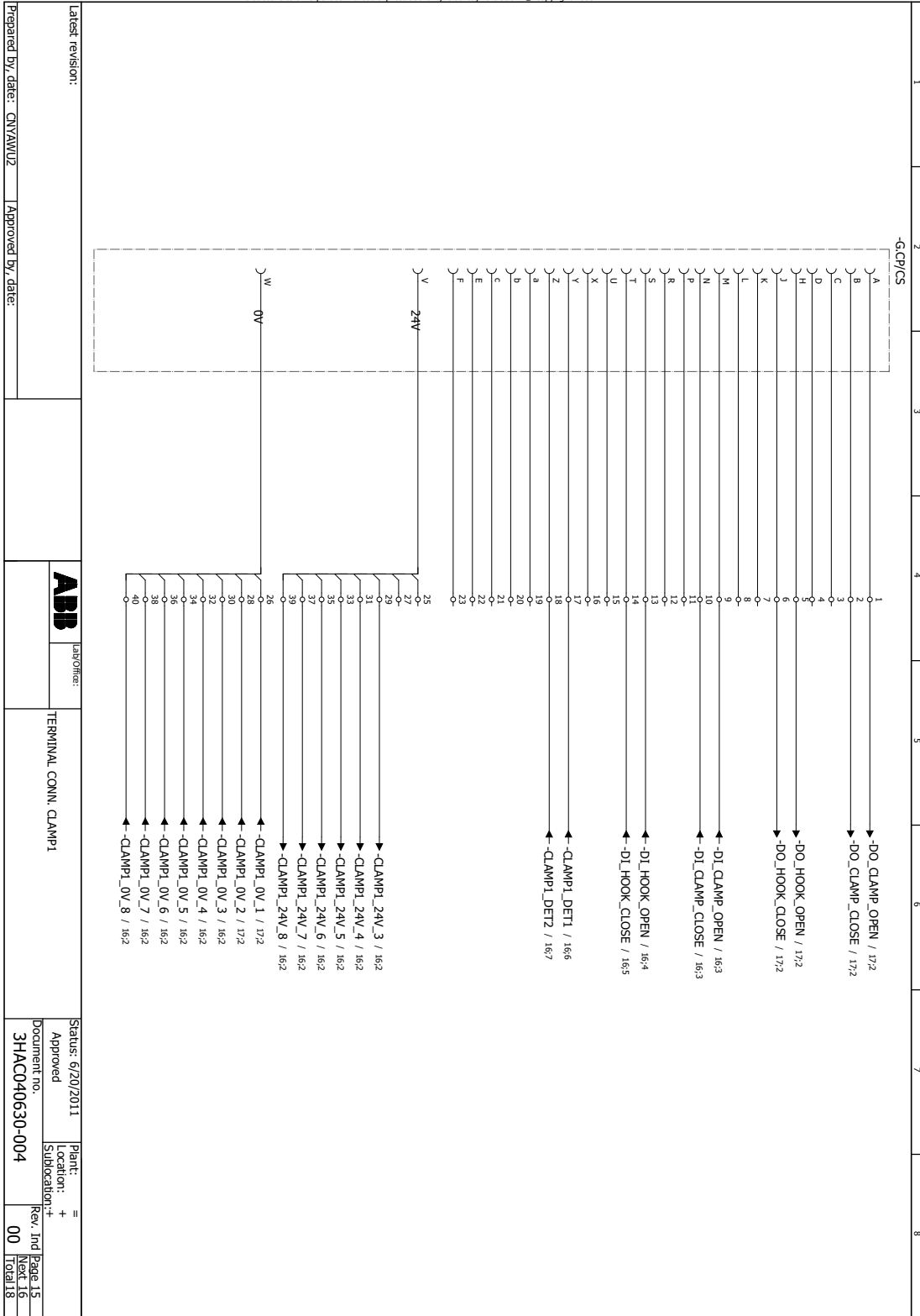

3HAC040149-003-20

Continues on next page

FlexGripper-Clamp 1 sensor connection

We reserve all rights in this document and in the information contained therein. Reproduction, use or disclosure to third parties without express authority is strictly forbidden. © Copyright 2003 ABB

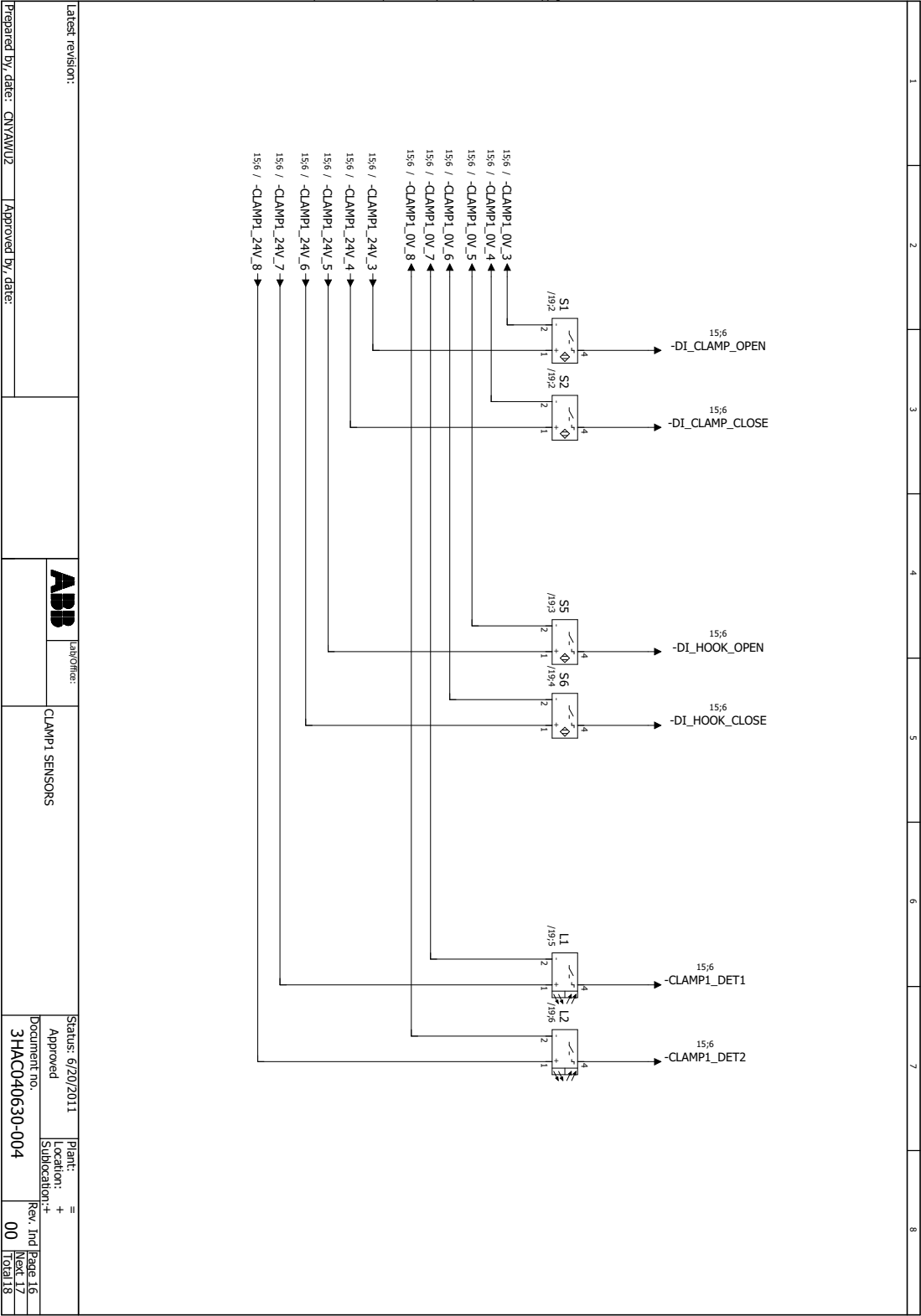

Latest revision:		Prepared by, date: CNVAVU2		Approved by, date:	
ABB		Lab/Office:		CLAMP1 SENSORS	
Status: 6/20/2011		Plant: +		Rev. Incl Page	
Approved		Location: +		Next 17	
Document no. 3HAC040630-004		Sublocation: +		Total 18	
		Rev. 00			

3HAC040149-003-21

FlexGripper-Clamp 2 DI

We reserve all rights in this document and in the information contained therein. Reproduction, use or disclosure to third parties without express authority is strictly forbidden. © Copyright 2003 ABB

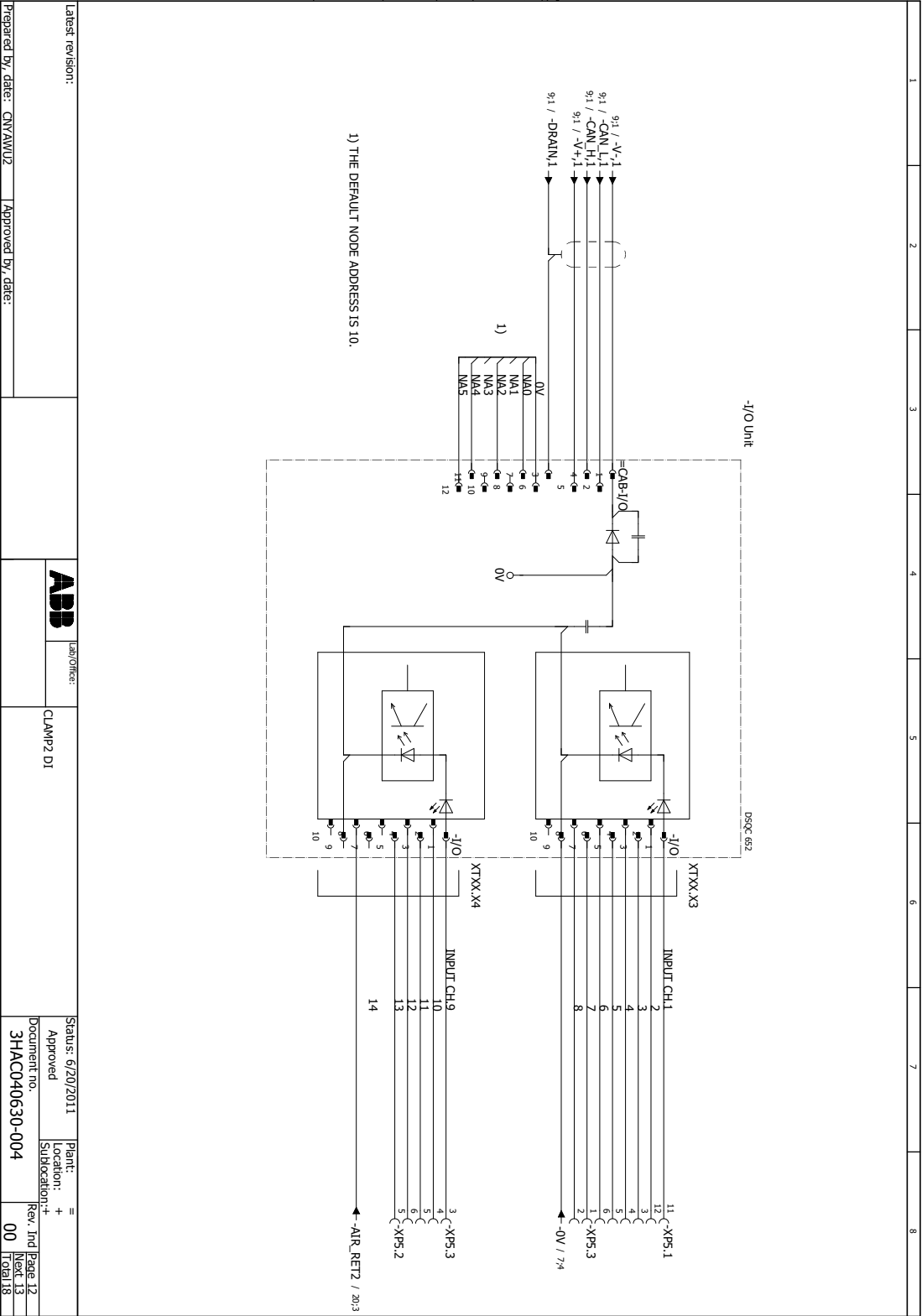

Latest revision:		Part:	=
Prepared by: date: QNYANWU2	Approved by: date:	Location:	+
		Sublocation:	+
		Rev. Incl	Page 12
		Document no:	3HAC040630-004
		Rev. Incl	Page 13
		Total	18

FlexGripper-Clamp 2 sensor connection

We reserve all rights in this document and in the information contained therein. Reproduction, use or disclosure to third parties without express authority is strictly forbidden. © Copyright 2003 ABB

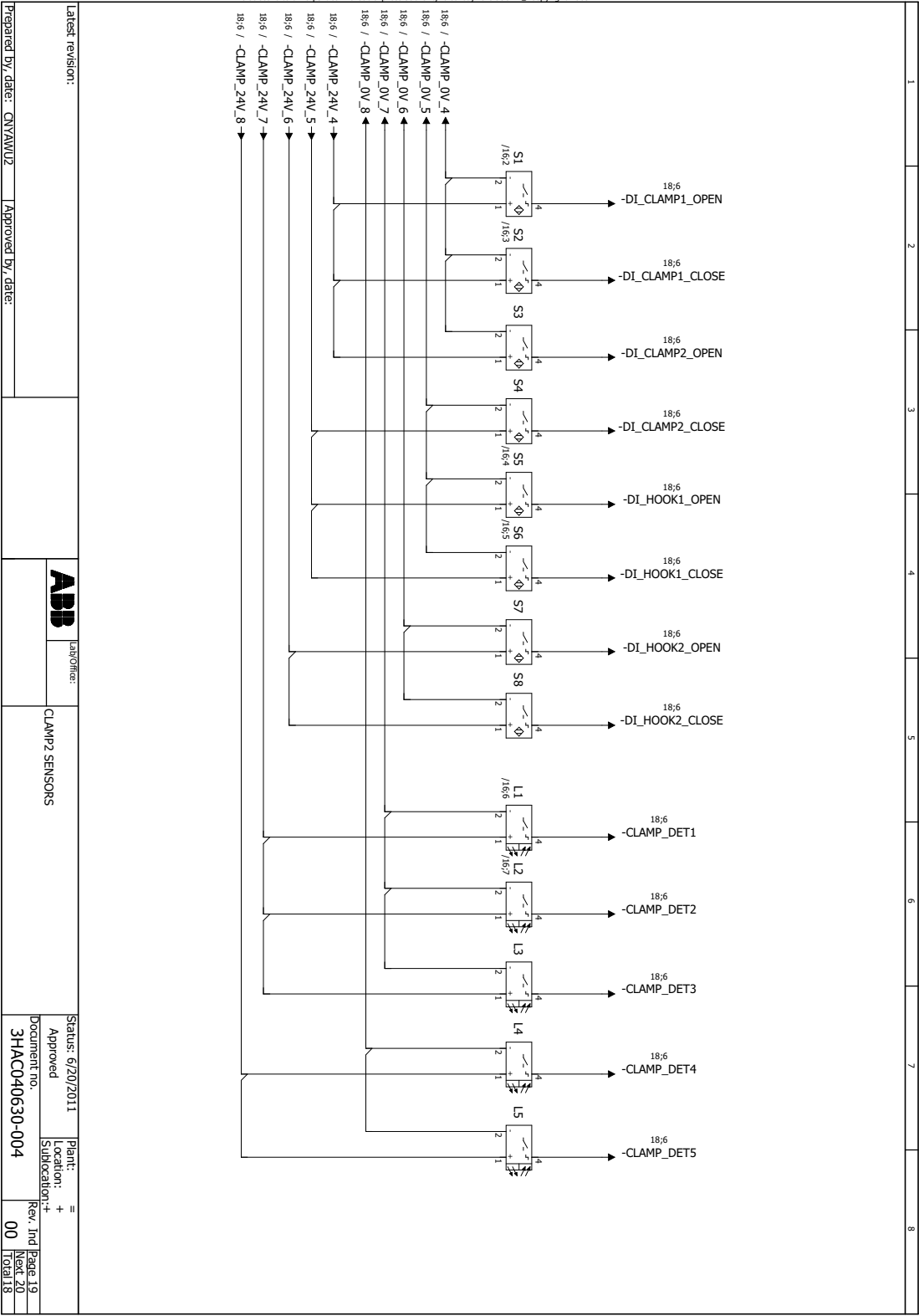

Latest revision:		Status: 6/20/2011	
Prepared by: date: CHYAWU2		Approved: +	
Approved by: date:		Plant: =	
ABB		Location: +	
CLAMP2 SENSORS		Substitution: +	
Document no. 3HAC040630-004		Rev. Inl Page 19	
00		Next 20	
Total 18			

3HAC040149-003-24

2 FlexGripper-Clamp

2.10.1. Electrical circuit

Continued

DRESSPACK IRB660

We reserve all rights in this document and in the information contained therein. Reproduction, use or disclosure to third parties without express authority is strictly forbidden. © Copyright 2003 ABB

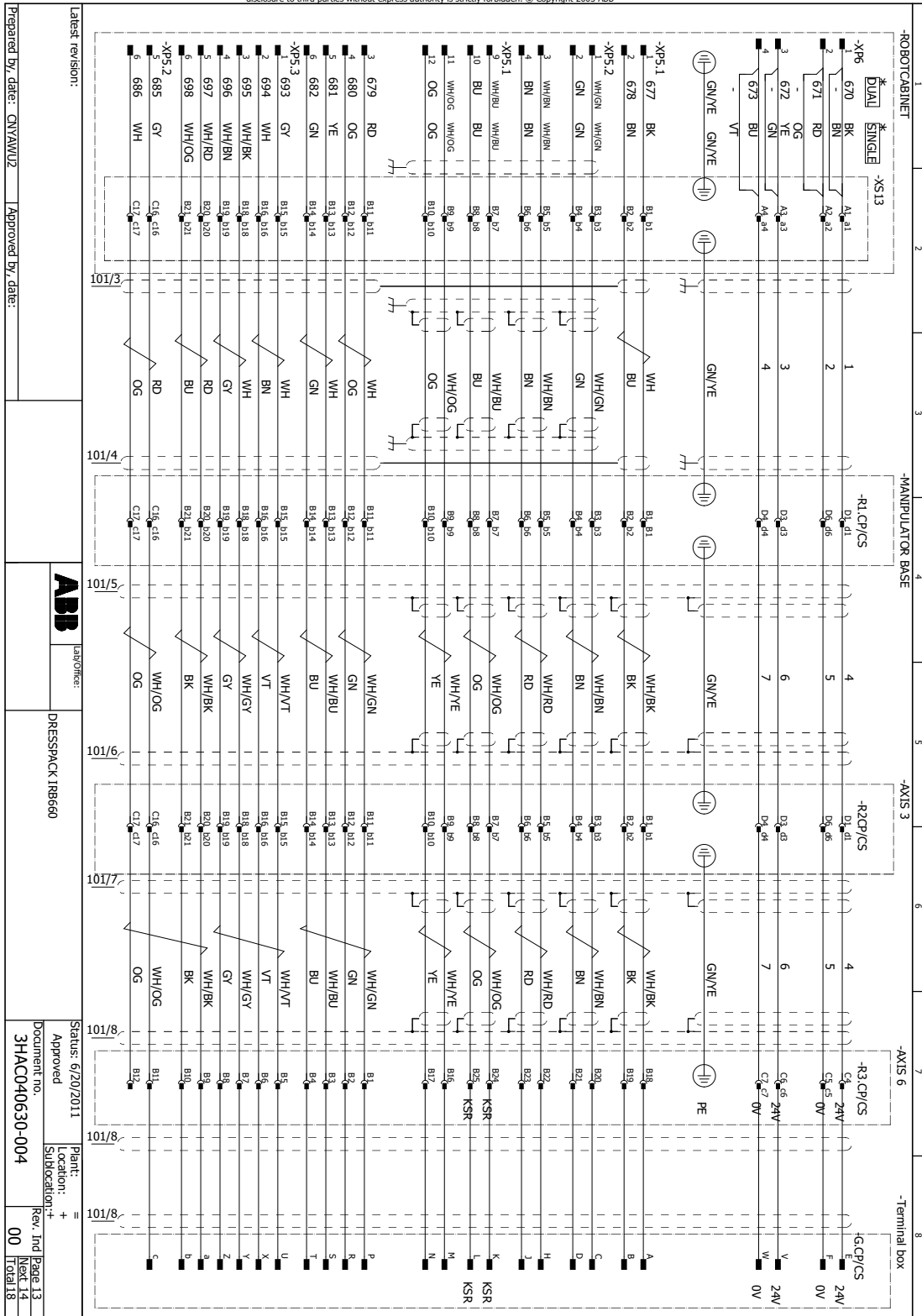

Latest revision:
Prepared by, date: GUYANUJ2 Approved by, date:

ABB
DRESSPACK IRB660

Status: 6/20/2011
Approved
Document no. 3HAC040630-004
Plant: +
Location: +
Sublocation: +
Rev. Ind Page 13
Total 18

3HAC040149-003-17

Continues on next page

3HAC040630-002 Revision: -

DRESSPACK IRB460 only for FlexGripper-Clamp 1

We reserve all rights in this document and in the information contained therein. Reproduction, use or disclosure to third parties without express authority is strictly forbidden. © Copyright 2003 ABB

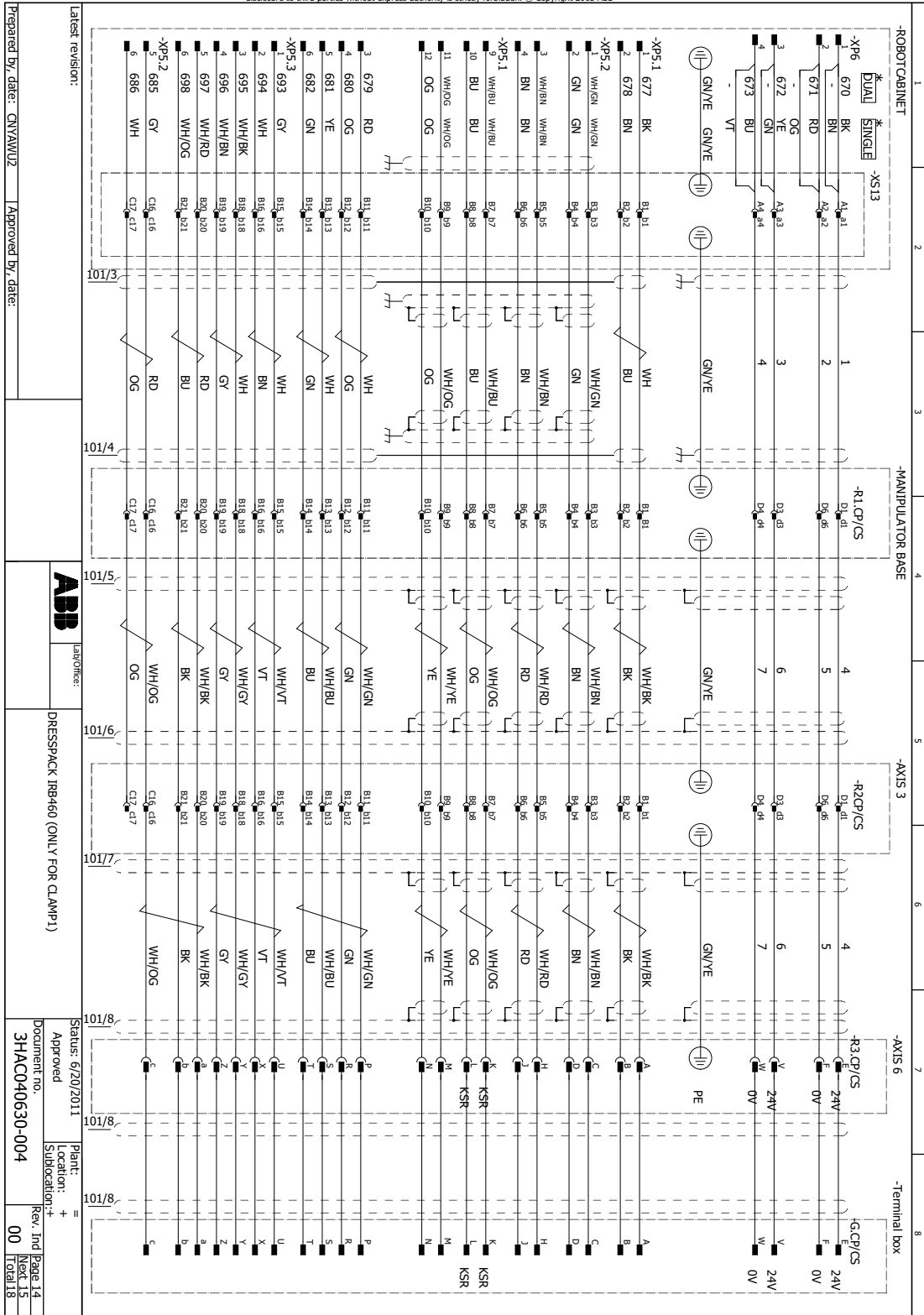

2 FlexGripper-Clamp

2.10.2. Pneumatic circuit

2.10.2. Pneumatic circuit

FlexGripper-Clamp 1 pneumatic circuit

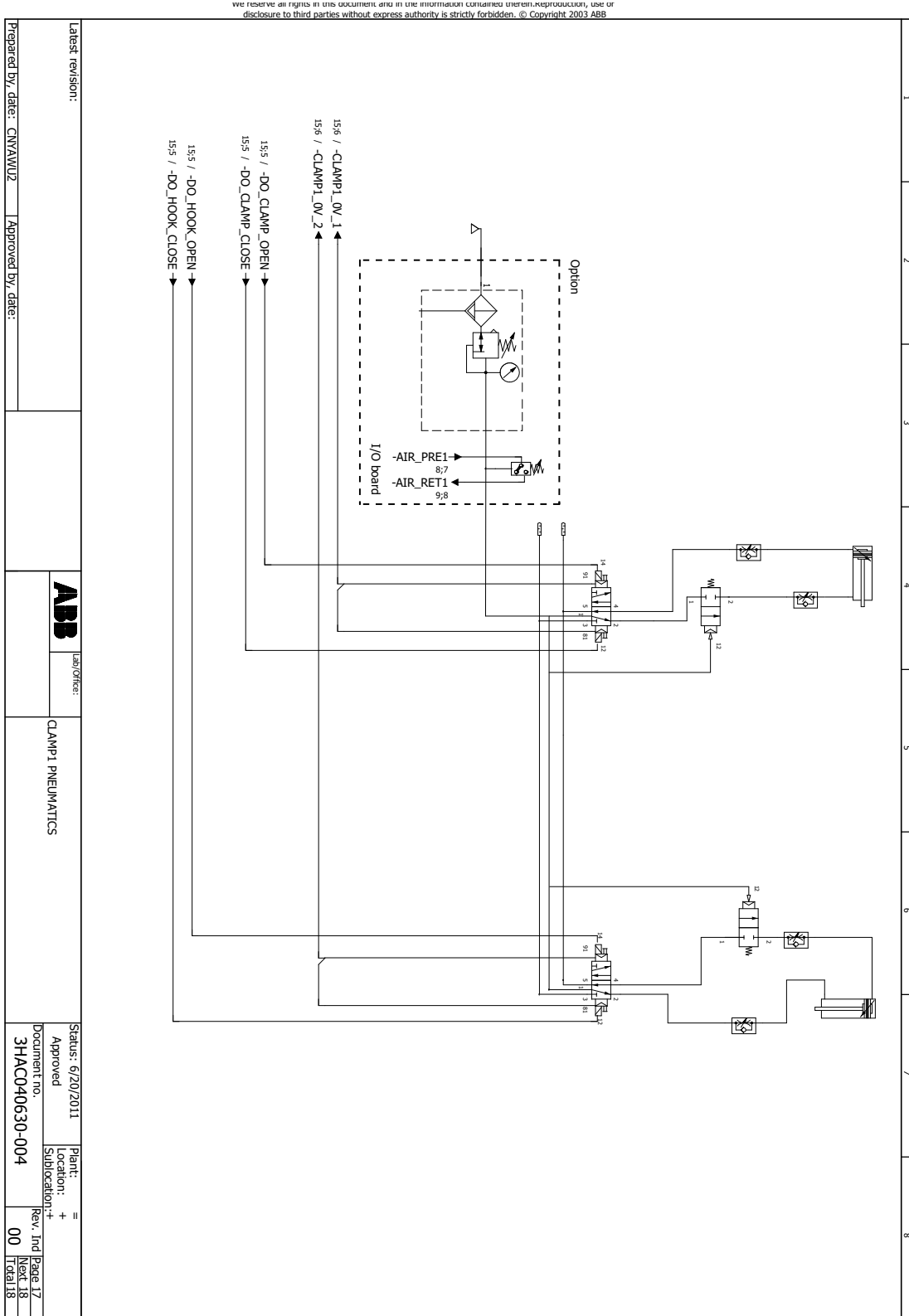

Continues on next page

FlexGripper-Clamp 2 pneumatic circuit

We reserve all rights in this document and in the information contained therein. Reproduction, use or disclosure to third parties without express authority is strictly forbidden. © Copyright 2003 ABB

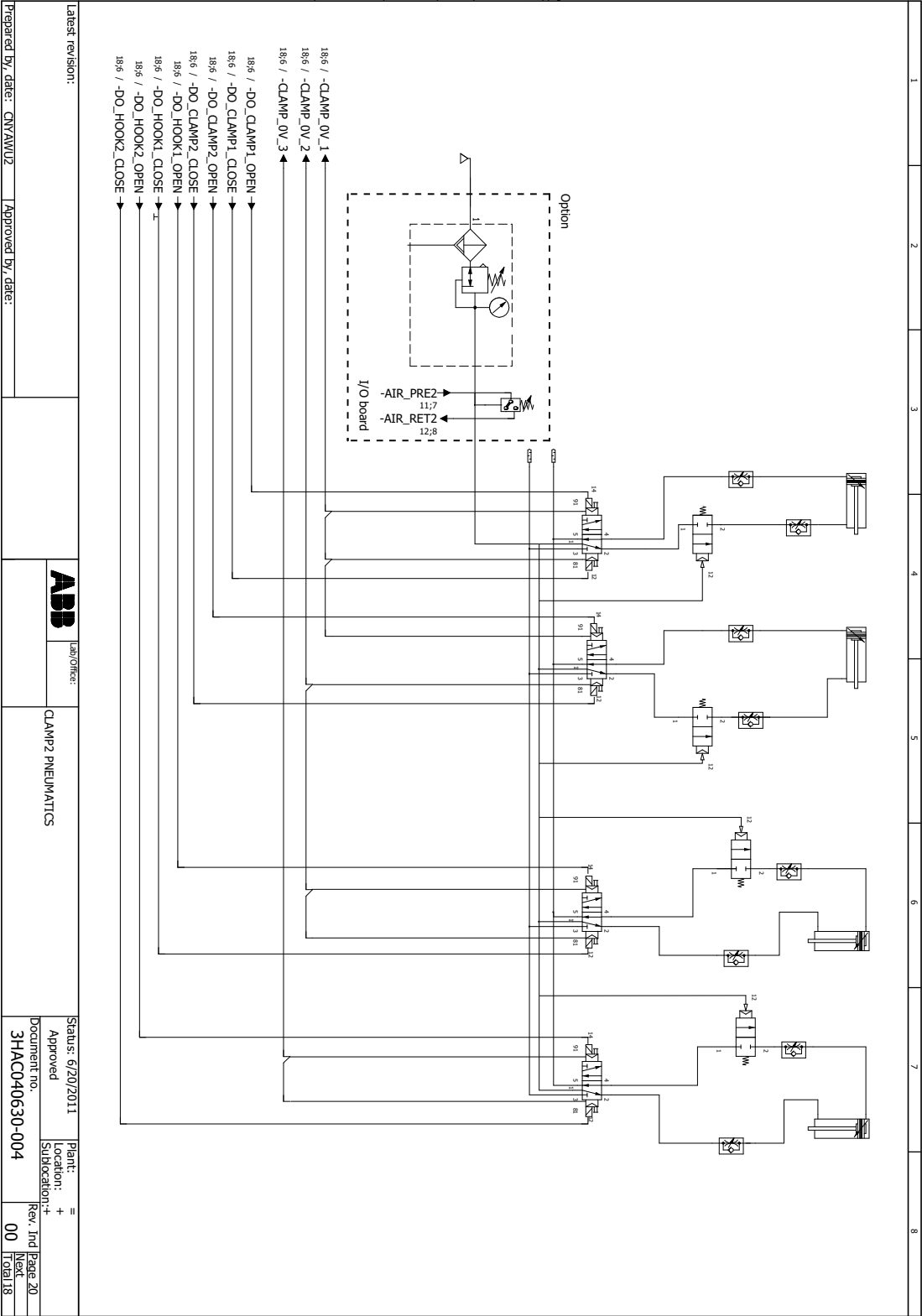

Latest revision:

Prepared by: date: CHYAWU2 Approved by: date:



Lab/Office:

CLAMP2 PNEUMATICS

Status: 6/20/2011

Approved

Document no:

3HAC040630-004

Plant:

Location:

Sublocation:

Rev. Ind

00

Page 20

Next

Total 18

2 FlexGripper-Clamp

2.10.2. Pneumatic circuit

3 FlexGripper UI

3 FlexGripper UI

3.1.1. Installing FlexGripper UI FlexPendant application

3.1 Software installation

3.1.1. Installing FlexGripper UI FlexPendant application



NOTE!

Only 24V power is used in FlexGripper.

Short circuit protection should be implemented by a fuse in the control cabinet by the customer.

Robot controller configuration requirement

Hardware	DSQC 652 board
RobotWare	RobotWare 5.13.02, includes the following options: <ul style="list-style-type: none">• 617-1 FlexPendant Interface

FlexGripper UI FlexPendant application installation

Use the following procedure:



NOTE!

Before installing FlexGripper UI FlexPendant application, make sure that you have RobotStudio installed on your laptop.

1. Copy the FlexGripperUI folder into the mediapool folder of your laptop. Copy the MULTIFLEXGRIPPERUI folder from the FlexGripperUI FlexPendant GUI installation CD to C:\Program Files\ABB Industrial IT\Robotics IT\Mediapool on your laptop (If the path to mediapool folder is not as above, find the mediapool folder on your PC).

2. Create a robot controller system for FlexGripperUI with RobotStudio.

- On the Online ribbon-tab of RobotStudio, click System Builder to bring up a dialog box.
- In the Actions group click Create New... to start the wizard.
- Follow the instructions on the wizard to enter a name and path of the system, then enter a controller key and a drive key for the system.
- In the Add Additional Options page, browse and select the FlexGripperUI option key from C:\Program Files\ABB Industrial IT\Robotics IT\Mediapool\MULTIFLEXGRIPPERUI\Internal_Use_Key. Then click the arrow to add the FlexGripperUI option key to the Added options list. Click Next to go to the next page.
- In the Modify Options page, make sure the following options are selected: a DeviceNet option (according to your hardware configuration), 616-1 PC Interface, 617-1 FlexPendant Interface and MULTIFLEXGRIPPERUI.
- Click Finish. The controller system is created. See Operating manual - RobotStudio for more detailed information.

Continues on next page

Continued

3. Download the system to robot controller.
4. Warm start the controller.

The FlexGripperUI application icon is shown on the ABB main menu on the FlexPendant.

Note: For the FlexGripper UI option, Singleclamp option represents FlexGripper-Clamp 1, Twoclamp option represents FlexGripper-Clamp 2, Vacuum option represents FlexGripper-Vacuum, Claw option represents FlexGripper-Claw.

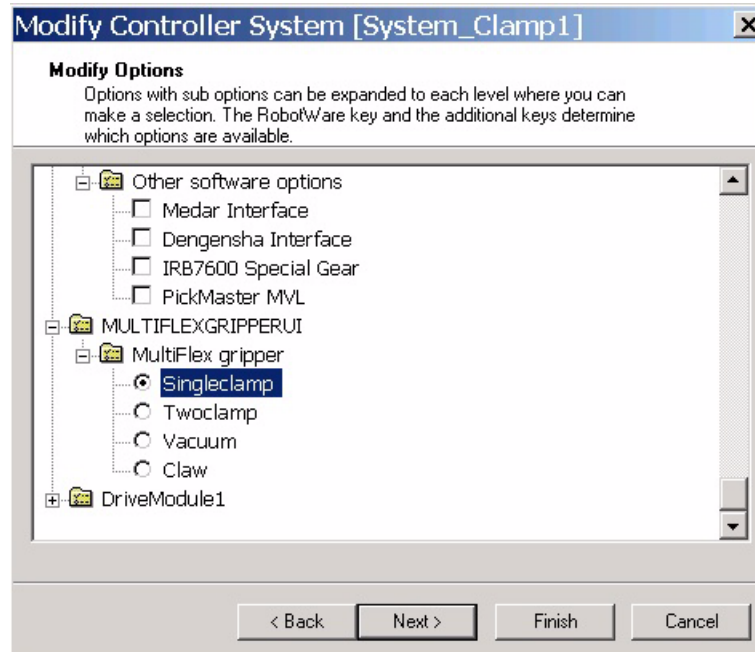

en1011047

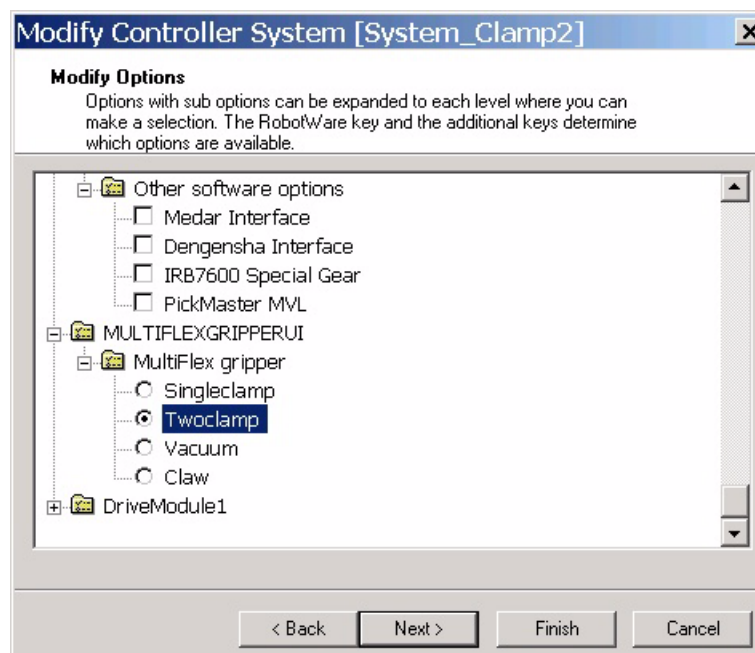

en1011047

3 FlexGripper UI

3.1.2. I/O signal configuration

3.1.2. I/O signal configuration

FlexGripper-Clamp 1 signal configuration

I/O signal	I/O board	Controller	Electric box		
			Signal	24V	0V
DO1001(DO10_01_ClampCylinder1_Open)	DO1	XT5.1.1	1	-	26
DO1002(DO10_02_ClampCylinder1_Close)	DO2	XT5.1.2	2		26
Spare		XT5.2.1	3		
Spare		XT5.2.2	4		
DO1005(DO10_05_HookCylinder1_Open)	DO5	XT5.2.3	5		28
DO1006(DO10_06_HookCylinder1_Close)	DO6	XT5.2.4	6		28
Spare		XT5.1.9	7		
Spare		XT5.1.10	8		
DI1001(DI10_01_ClampCylinder1_Opened)	DI1	XT5.1.11	9	31	32
DI1002(DI10_02_ClampCylinder1_Closed)	DI2	XT5.1.12	10	31	32
Spare		XT5.1.3	11		
Spare		XT5.1.4	12		
DI1005(DI10_05_HookCylinder1_Opened)	DI5	XT5.1.5	13	33	34
DI1006(DI10_06_HookCylinder1_Closed)	DI6	XT5.1.6	14	33	34
Spare		XT5.3.1	15		
Spare		XT5.3.2	16		
DI1009(DI10_09_PartDetection1)	DI9	XT5.3.3	17	37	38
DI1010(DI10_10_PartDetection2)	DI10	XT5.3.4	18	37	38
Spare		XT5.3.5	19		
Spare		XT5.3.6	20		
Spare		XT5.2.5	21		
Spare		XP6.1	22		
DI1015(DI10_15_AirPressure)m, for detect compressed air source pressure	DI5	XP6.2	23	25	
	24V	XP6.3			
	0V	XP6.4			

FlexGripper-Clamp 2 signal configuration

I/O signal	I/O board	Controller	Electric box		
			Signal	24V	0V

Continues on next page

Continued

DO1001(DO10_01_ClampCylinder1_Open)	DO1	XT5.1.1	1	-	26
DO1002(DO10_02_ClampCylinder1_Close)	DO2	XT5.1.2	2		26
DO1003(DO10_03_ClampCylinder2_Open)	DO3	XT5.2.1	3		26
DO1004(DO10_04_ClampCylinder2_Close)	DO4	XT5.2.2	4		28
DO1005(DO10_05_HookCylinder1_Open)	DO5	XT5.2.3	5		28
DO1006(DO10_06_HookCylinder1_Close)	DO6	XT5.2.4	6		28
DO1007(DO10_07_HookCylinder2_Open)	DO7	XT5.1.9	7		30
DO1008(DO10_08_HookCylinder2_Close)	DO8	XT5.1.10	8		30
DI1001(DI10_01_ClampCylinder1_Opened)	DI1	XT5.1.11	9	31	32
DI1002(DI10_02_ClampCylinder1_Closed)	DI2	XT5.1.12	10	31	32
DI1003(DI10_03_ClampCylinder2_Opened)	DI3	XT5.1.3	11	31	32
DI1004(DI10_04_ClampCylinder2_Closed)	DI4	XT5.1.4	12	33	34
DI1005(DI10_05_HookCylinder1_Opened)	DI5	XT5.1.5	13	33	34
DI1006(DI10_06_HookCylinder1_Closed)	DI6	XT5.1.6	14	33	34
DI1007(DI10_07_HookCylinder2_Opened)	DI7	XT5.3.1	15	35	36
DI1008(DI10_08_HookCylinder2_Closed)	DI8	XT5.3.2	16	35	36
DI1009(DI10_09_PartDetection1)	DI9	XT5.3.3	17	37	38
DI1010(DI10_10_PartDetection2)	DI10	XT5.3.4	18	37	38
DI1011(DI10_11_PartDetection3)	DI11	XT5.3.5	19	37	38
DI1012(DI10_12_PartDetection4)	DI12	XT5.3.6	20	39	40
DI1013(DI10_13_PartDetection5)	DI13	XT5.2.5	21	39	40
Spare		XP6.1	22		
DI1015(DI10_15_AirPressure), for detect compressedair sourcepressure	DI15	XP6.2	23	25	
	24V	XP6.3			
	0V	XP6.4			

3.1.3. Back-up and I-Start

Back up the system

Use this procedure to back up your system:



NOTE!

We recommend performing a backup:

- Before installing a new RobotWare.
- Before making any major changes to instructions and/or parameters to make it possible to return to the previous settings.
- After making any major changes to instructions and/or parameters and testing the new settings to retain the new successful setting.

1. Tap the ABB menu and then tap Backup and Restore.
2. Tap Backup Current System....A page showing the selected path opens.
3. Specify a backup folder name and path.
4. Tap Backup.

A backup folder is created according to your settings.

Restart and return to default setting (I-start)

Use this procedure to make an I-start



NOTE!

After I-start, the system's state will be resumed but any changes done to system parameters and other settings will be lost. Instead, system parameters and other settings are read from the originally installed system on delivery. Therefore it is important to always make a back up before I-start.

1. Make a backup of the system.
2. On the ABB menu, tap Restart. The restart page is displayed.
3. Tap Advanced... to select restart method. The select restart method dialog is displayed.
4. Tap I-start, then tap OK.
5. Restore the backup system.

3.2 Operation

3.2.1. FlexGripper UI main interface

Enter FlexGripper UI

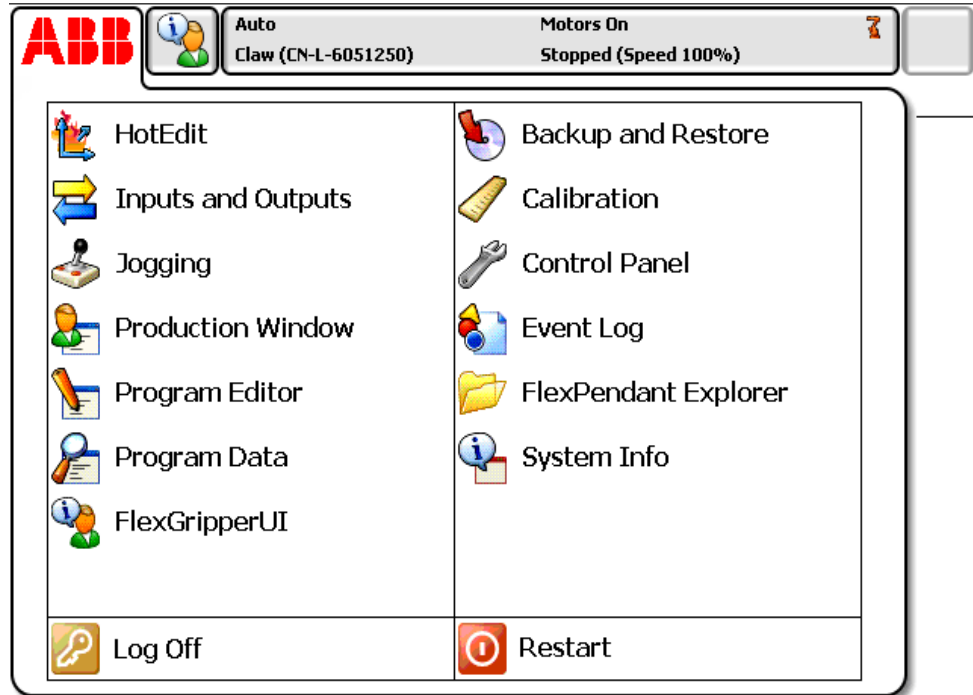

en1011048

The FlexGripper UI has three function blocks: Tool handle, TCP edit and Production which you can see after entering the main interface.



en1011049

3 FlexGripper UI

3.2.2.1. FlexGripper function test

3.2.2. Tool handle

3.2.2.1. FlexGripper function test

FlexGripper-Clamp (FlexGripper-Clamp 1) function test

Touch the Tool handle button, the following interface shows.

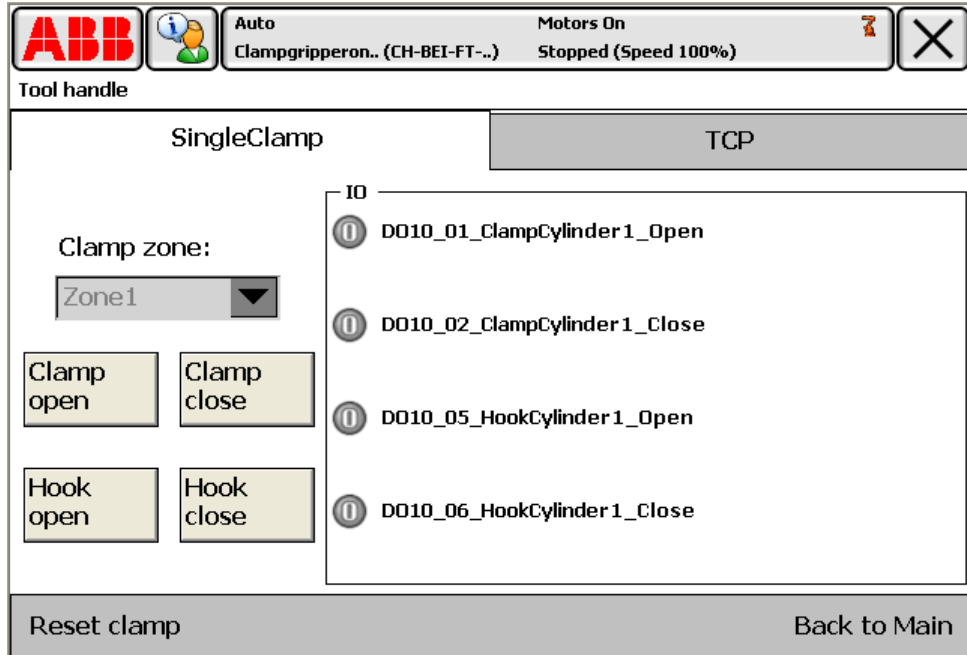

en1011053

You can operate the functions displayed to check if the corresponding signals status is correct. The functions displayed are Clamp open, Clamp close, Hook open and Hook close.

Function and signal status (FlexGripper-Clamp 1)

Function name	Action description	Signal status
Clamp open	Clamp cylinder pulls out and clamp open.	DO10_01_ClampCylinder1_Open turns to 1 and lights up
Clamp close	Clamp cylinder pulls back and clamp close.	DO10_02_ClampCylinder1_Close turns to 1 and lights up
Hook open	Hook cylinder pulls back and hook open.	DO10_05_HookCylinder1_Opened turns to 1 and lights up
Hook close	Hook cylinder pulls out and hook close.	DO10_06_HookCylinder1_Closeed turns to 1 and lights up
Reset clamp	All settings are reset to factory setting.	All signals turn to 0 and all lights turn off.
Product drop detection	To detect if the product drops. When the product is gripped, the corresponding photoelectric sensor remains lit.	If one of the products drops, the corresponding signal in DI10_09_PartDetection1 DI10_10_PartDetection2 would turn to 0 and turn off.

Continues on next page

Continued**NOTE!**

After entering the main interface and touching any of the buttons, a warning message shows prompting converting to manual mode.

Switch the control mode from auto mode to manual mode, the operations are now available. Touch Back to Main button, the interface returns to the main interface.

FlexGripper-Clamp (FlexGripper-Clamp 2) function test

Touch the Tool handle button, the following interface shows.

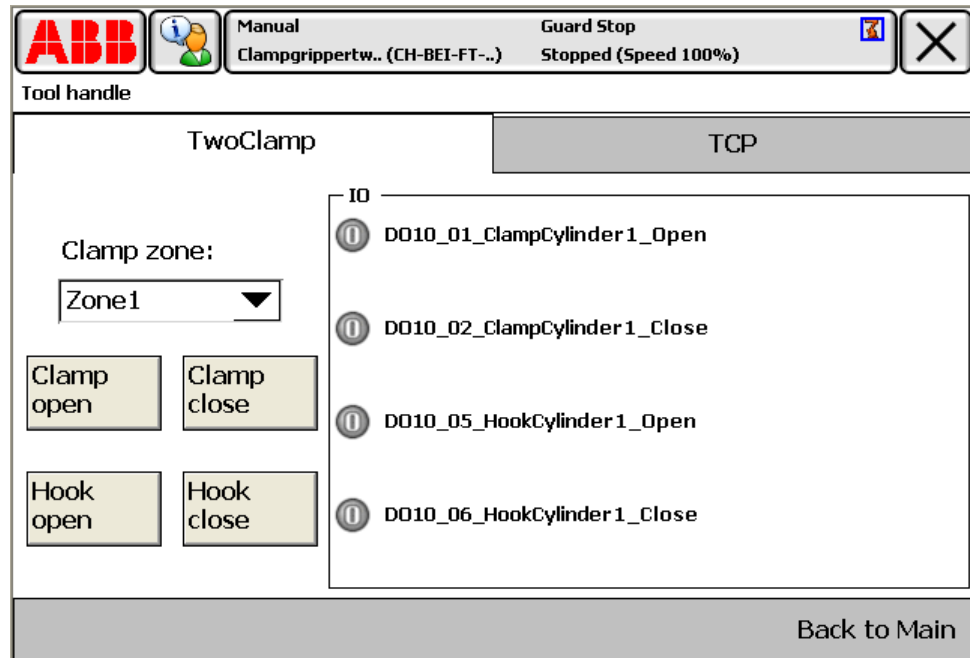

en1011054

Continues on next page

3 FlexGripper UI

3.2.2.1. FlexGripper function test

Continued

Users can operate the functions displayed and check if the corresponding signals status is correct. With the Clamp zone dropdown list, users can choose Zone1, Zone2 or Both zones to do the corresponding function test.

Function and signal status table (FlexGripper-Clamp 2)

Function type	Function name	Action description	Signal status
Zone 1	Clamp open	Clamp cylinder pulls out and the clamp opens.	DO10_01_ClampCylinder1_Opened turns to 1 and lights up
	Clamp close	Clamp cylinder pulls back and the clamp closes.	DO10_02_ClampCylinder1_Closed turns to 1 and lights up
	Hook open	Hook cylinder pulls back and the hook opens.	DO10_05_HookCylinder1_Opened turns to 1 and lights up
	Hook close	Hook cylinder pulls out and the hook closes.	DO10_06_HookCylinder1_Closed turns to 1 and lights up
	Product drop detection	To detect if the product drops. When the product is gripped, the corresponding photoelectric sensor remains lit.	If one of the products drops, the corresponding signal in DI10_09_PartDetection1 DI10_10_PartDetection2 DI10_11_PartDetection3 DI10_12_PartDetection4 DI10_13_PartDetection5 would turn to 0 and turn off.
Zone 2	Clamp open	Clamp cylinder pulls out and the clamp opens.	DO10_03_ClampCylinder2_Opened turns to 1 and lights up
	Clamp close	Clamp cylinder pulls back and the clamp closes.	DO10_04_ClampCylinder2_Closed turns to 1 and lights up
	Hook open	Hook cylinder pulls back and the hook opens.	DO10_07_HookCylinder2_Opened turns to 1 and lights up
	Hook close	Hook cylinder pulls out and the hook closes.	DO10_08_HookCylinder2_Closed turns to 1 and lights up
	Product drop detection	To detect if the product drops. When the product is gripped, the corresponding photoelectric sensor remains lit.	If one of the products drops, the corresponding signal in DI10_09_PartDetection1 DI10_10_PartDetection2 DI10_11_PartDetection3 DI10_12_PartDetection4 DI10_13_PartDetection5 would turn to 0 and turn off.

Continues on next page

Continued

Function type	Function name	Action description	Signal status
Both zones	Clamp open	Both clamp cylinders pull out and both clamps open.	DO10_01_ClampCylinder1_Opened and DO10_03_ClampCylinder2_Opened turn to 1 and lights up
	Clamp close	Both clamp cylinders pull back and both clamps close.	DO10_02_ClampCylinder1_Closed and DO10_04_ClampCylinder2_Closed turn to 1 and lights up
	Hook open	Both hook cylinders pull back and both hooks open.	DO10_05_HookCylinder1_Opened and DO10_07_HookCylinder2_Opened turn to 1 and lights up
	Hook close	Both hook cylinders pull out and both hooks close.	DO10_06_HookCylinder1_Closed and DO10_08_HookCylinder2_Closed turn to 1 and lights up
	Product drop detection	To detect if the product drops. When the product is gripped, the corresponding photoelectric sensor remains lit.	If one of the products drops, the corresponding signal in DI10_09_PartDetection1 DI10_10_PartDetection2 DI10_11_PartDetection3 DI10_12_PartDetection4 DI10_13_PartDetection5 would turn to 0 and turn off.
Reset	Reset clamp	All settings are reset to factory settings.	All signals turn to 0 and all lights turn off.



NOTE!

After entering the main interface and touching any of the buttons, a warning message would show prompting converting to manual mode.

Switch the control mode from auto mode to manual mode, the operations are now available. Touch Back to Main button, the interface returns to the main interface..

3 FlexGripper UI

3.2.2.2. TCP edit

3.2.2.2. TCP edit

Note: The TCP configuration includes three elements: TASK, Storage type and Scope.

Their scopes are:

Task: T_ROB1

Storage type: Persistent and variable

Scope: Task, Global and Local

If the scope and storage type of the TCP is not correct it can not be monitored.

Touch TCP tab, the following interface would shows:

The screenshot displays the ABB FlexGripper TCP configuration interface. At the top, there is a status bar with the ABB logo, system information 'Auto System_VACUUM.. (CH-BEI-FT..)', motor status 'Motors On Stopped (Speed 100%)', and a close button. Below the status bar is the 'Tool handle' section, which includes a 'Vacuum' tab and a 'TCP' tab. The 'TCP' tab is selected, showing a 'Current TCP:' field and a 'Select TCP' button. The main configuration area is divided into two columns: 'Tool' and 'Load'. The 'Tool' column contains fields for 'trans x:', 'trans y:', 'tran z:', 'rot q1:', 'rot q2:', 'rot q3:', and 'rot q4:'. The 'Load' column contains fields for 'mass:', 'cog x:', 'cog y:', 'cog z:', 'inertia x:', 'inertia y', and 'inertia z:'. At the bottom of the interface, there are three buttons: 'Edit TCP', 'Apply', and 'Back to Main'.

en1011057

The grey column indicates data columns are not editable. The white columns indicate they are in editable mode.

Continues on next page

TCP operation

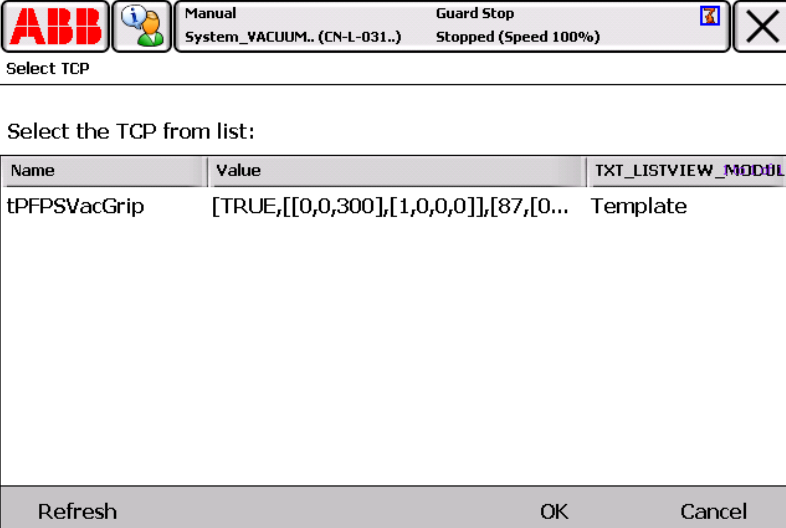
Action	Procedure						
Select TCP	<p>Touch Select TCP button, then the TCP list shows.</p>  <p>Select the TCP from list:</p> <table border="1"> <thead> <tr> <th>Name</th> <th>Value</th> <th>TXT_LISTVIEW_MODULE</th> </tr> </thead> <tbody> <tr> <td>tPFPSVacGrip</td> <td>[TRUE,[[0,0,300],[1,0,0,0]],[87,[0...</td> <td>Template</td> </tr> </tbody> </table> <p>Refresh OK Cancel</p>	Name	Value	TXT_LISTVIEW_MODULE	tPFPSVacGrip	[TRUE,[[0,0,300],[1,0,0,0]],[87,[0...	Template
Name	Value	TXT_LISTVIEW_MODULE					
tPFPSVacGrip	[TRUE,[[0,0,300],[1,0,0,0]],[87,[0...	Template					

en1011058

Select the TCP needed, and touch OK. The related parameters of the TCP are automatically loaded into the Tool field on the left and the Load field on the right.

Edit TCP Choose the “Edit TCP” button, the column turns from grey to white indicating the content is editable. Choose one field, a soft keyboard shows which is used to input TCP data.

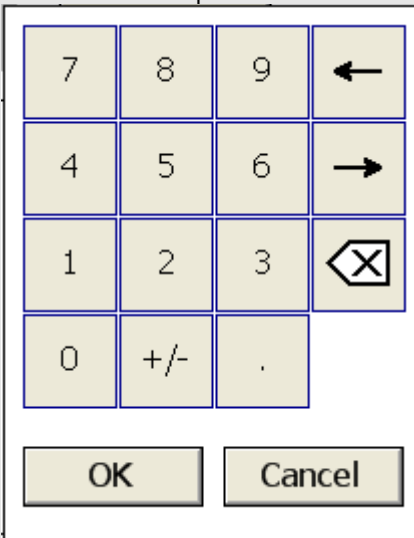

en1011059

The soft keyboard consists of 0-9 numbers, positive/negative sign (+/-), decimal point, and an arrow left/right symbol used to move cursor left/right. The cross button has the function of backspace. For data description and valid data scope, see Table TCP Parameter description, After the editing, touch OK to confirm the editing. Then touch Apply, the editing is saved which is indicated by the data input columns turning grey.

3 FlexGripper UI

3.2.2.2. TCP edit

Continued

TCP Parameter description

Type	Parameter	Description
Tool	trans x	The X-value of TCP position in mm
	trans y	The Y-value of TCP position in mm
	trans z	The Z-value of TCP position in mm
	rot q1	The q1 value in the quaternion (q1, q2, q3, q4) of the orientation of the tool coordinate system
	rot q2	The q2 value in the quaternion (q1, q2, q3, q4) of the orientation of the tool coordinate system
	rot q3	The q3 value in the quaternion (q1, q2, q3, q4) of the orientation of the tool coordinate system
	rot q4	The q4 value in the quaternion (q1, q2, q3, q4) of the orientation of the tool coordinate system
Load	mass	The weight of the tool in kg.
	cog x	The X-value of the center of gravity of the tool load (x, y and z) in mm
	cog y	The Y-value of the center of gravity of the tool load (x, y and z) in mm
	cog z	The Z-value of the center of gravity of the tool load (x, y and z) in mm
	inertia x	The X-value of the moments of inertia of the tool relative to its center of mass around the tool load coordinate axes in kgm ²
	inertia y	The Y-value of the moments of inertia of the tool relative to its center of mass around the tool load coordinate axes in kgm ²
	inertia z	The Z-value of the moments of inertia of the tool relative to its center of mass around the tool load coordinate axes in kgm ²

Continues on next page

Default TCP of FlexGrippers

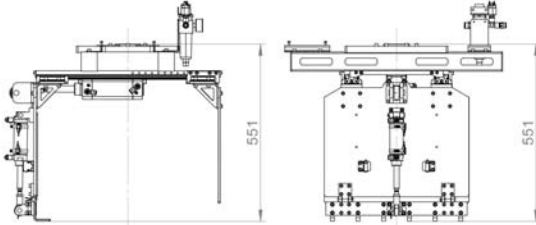
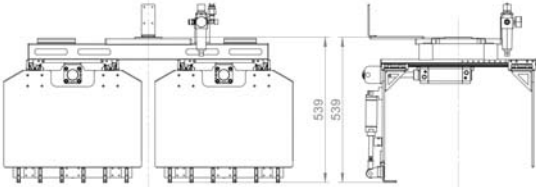
FlexGripper type	Default TCP value	Default TCP location illustration
FlexGripper per-Clamp 1	[TRUE, [[0,0,551], [1,0,0,0]], [39.7, [-15.5,-3.7,167.5], [1,0,0,0],0,0,0.973]]	 <p>en1011078</p>
FlexGripper per-Clamp 2	[TRUE, [[0,0,539], [1,0,0,0]], [74.9, [-18,-7.7,180.8], [1,0,0,0],6.152,0.557,7.603]]	 <p>en1011079</p>



NOTE!

The default TCP is only valid when no product is gripped by the FlexGripper. After the product is gripped, the TCP location should be adjusted according to the new center of gravity.

If the user wants to add a TCP themselves, they can add a TCP in the program. Then the newly added TCP can be shown in the TCP list when tapping Select TCP in the TCP interface.

3 FlexGripper UI

3.2.3.1. Position Tune

3.2.3. Tune

3.2.3.1. Position Tune

The position tune function is used to fine tune the robot target location as the pick/place location and home location.

Note: The robot target configuration includes three elements: TASK, Storage type and Scope.

Their scopes are:

Task: T_ROB1

Storage type: Persistent and variable

Scope: Task, Global and Local

If the scope and storage type of the robot target is not correct it can not be monitored.

Touch the Tune button in the FlexGripper UI main interface, and enter the Tune interface. By default, there are three robot targets listed: pPick, pPlace and pHome (For FlexGripper-Vacuum, there are three more targets: pPickPallet, pSearch and pSearchEnd).

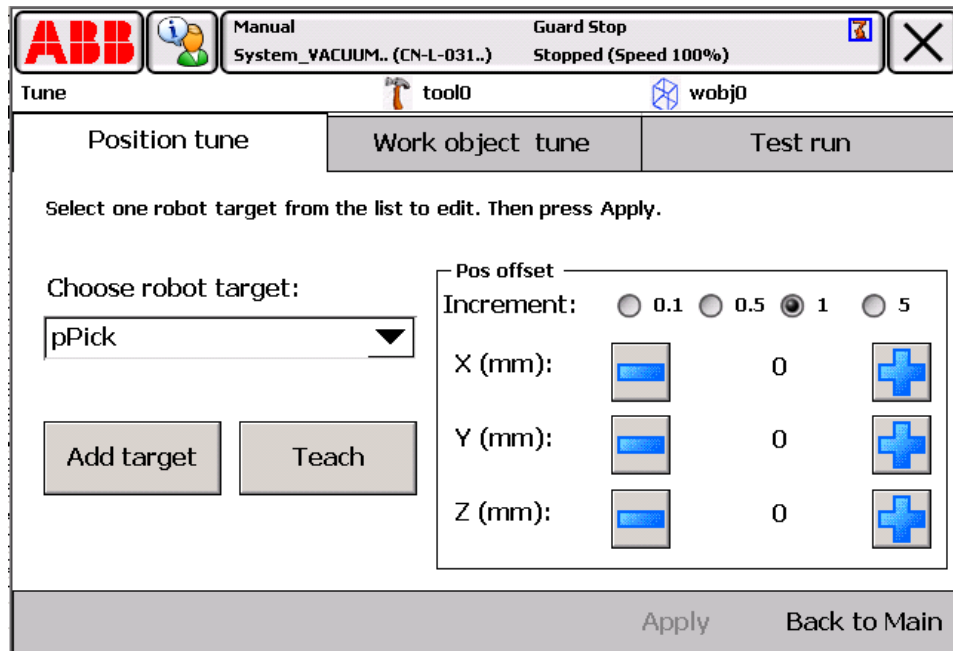

en1011060

Continues on next page

Continued

Robot target edit

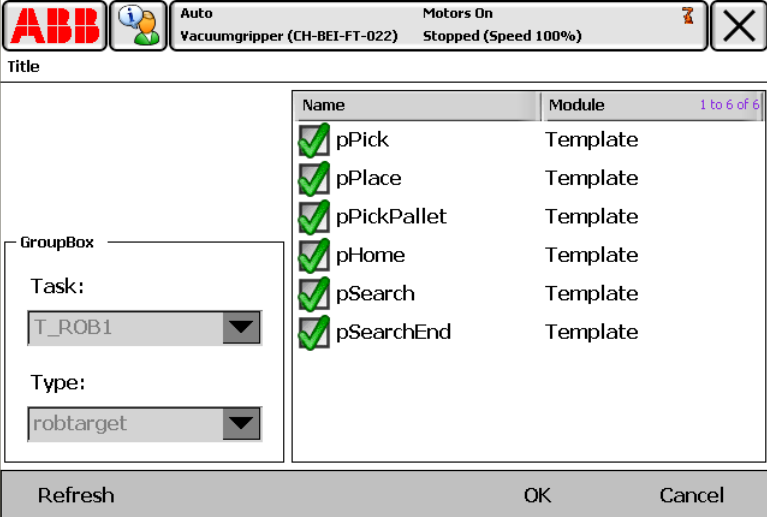
Action	Procedure														
Add target	<p>Touch the Add target button, in the screen shown, the left side shows the target contribution, ie Task, Type, the right side shows the target list with the module described. Select the target needed, which is then ticked in the square before its name.</p>  <table border="1" data-bbox="959 622 1437 992"> <thead> <tr> <th>Name</th> <th>Module</th> </tr> </thead> <tbody> <tr> <td><input checked="" type="checkbox"/> pPick</td> <td>Template</td> </tr> <tr> <td><input checked="" type="checkbox"/> pPlace</td> <td>Template</td> </tr> <tr> <td><input checked="" type="checkbox"/> pPickPallet</td> <td>Template</td> </tr> <tr> <td><input checked="" type="checkbox"/> pHome</td> <td>Template</td> </tr> <tr> <td><input checked="" type="checkbox"/> pSearch</td> <td>Template</td> </tr> <tr> <td><input checked="" type="checkbox"/> pSearchEnd</td> <td>Template</td> </tr> </tbody> </table> <p>Refresh OK Cancel</p> <p>en1011061</p> <p>The targets listed are selected by default. Touch the target to remove the tick and deselect a target. Select OK, the selected targets are added to the Choose robot target column.</p>	Name	Module	<input checked="" type="checkbox"/> pPick	Template	<input checked="" type="checkbox"/> pPlace	Template	<input checked="" type="checkbox"/> pPickPallet	Template	<input checked="" type="checkbox"/> pHome	Template	<input checked="" type="checkbox"/> pSearch	Template	<input checked="" type="checkbox"/> pSearchEnd	Template
Name	Module														
<input checked="" type="checkbox"/> pPick	Template														
<input checked="" type="checkbox"/> pPlace	Template														
<input checked="" type="checkbox"/> pPickPallet	Template														
<input checked="" type="checkbox"/> pHome	Template														
<input checked="" type="checkbox"/> pSearch	Template														
<input checked="" type="checkbox"/> pSearchEnd	Template														
Teach target	<p>Touch the Teach button, the selected robot target position is taught. Meanwhile the corresponding parameters of the TCP are automatically loaded into the Pos offset column.</p>														
Target position offset	<p>After target teach, if the robot doesn't reach the exact position, the offset function can be used to fine tune the robot target.</p> <p>In the Pos offset column, touching the plus sign increases the position in mm and the minus sign decreases it. The increment unit can be adjusted in 0.1mm, 0.5mm, 1mm or 5mm. After the offset, touch Apply, the offset target is saved.</p>														

3 FlexGripper UI

3.2.3.2. Work object tune

3.2.3.2. Work object tune

A work object is a coordinate system used to describe the position of a work piece. The work object consists of two frames: a user frame and an object frame. All programmed positions will be related to the object frame. The object frame is related to the user frame and the user frame is related to the world coordinate system.

Note: The work object configuration includes three elements: TASK, Storage type and Scope.

Their scopes are:

Task: T_ROB1

Storage type: Persistent and variable

Scope: Task, Global

If the scope and storage type of the work object is not correct it can not be monitored.

Touch the Work object tune tab to enter the work object tune interface.

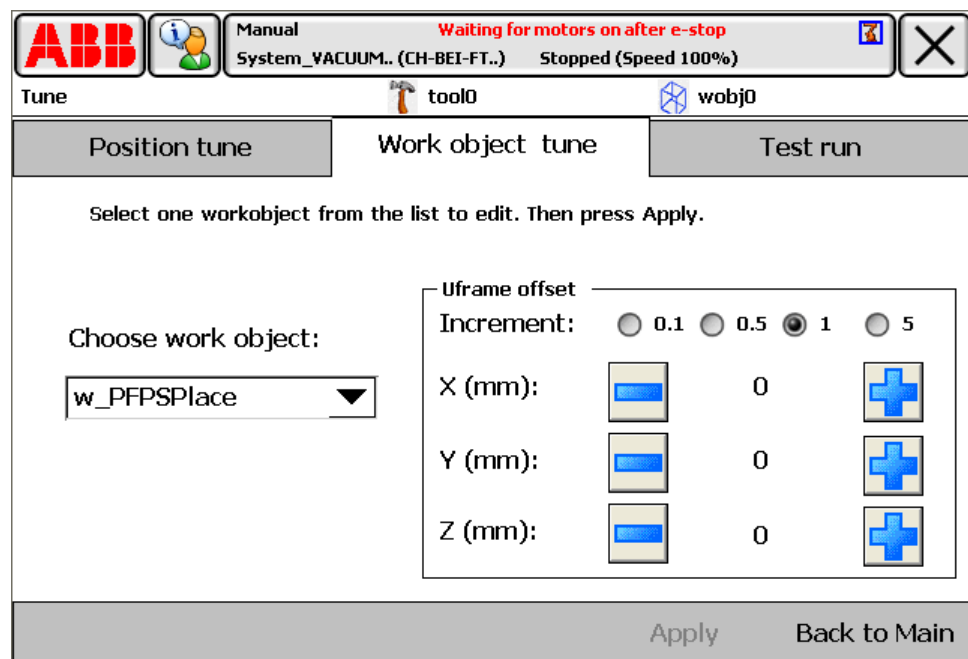

en1011062

Work object tune operation

Action	Procedure
Choose work target	Choose work object from the drop down list on the left. The work object (x, y, z) in mm shows up on the right.
Tune the work object	Touch the minus button to decrease the value and the plus button to increase the value. The tuning unit can be 0.1mm, 0.5mm, 1mm or 5 mm. After editing, touch Apply, the modification is saved.

3.2.3.3. Test run

After the TCP edit, Position tune and work object tune, the functions defined in the Template system module can be tested in Test run. For FlexGripper-Clamp, after entering the Test run interface, the following interface shows:

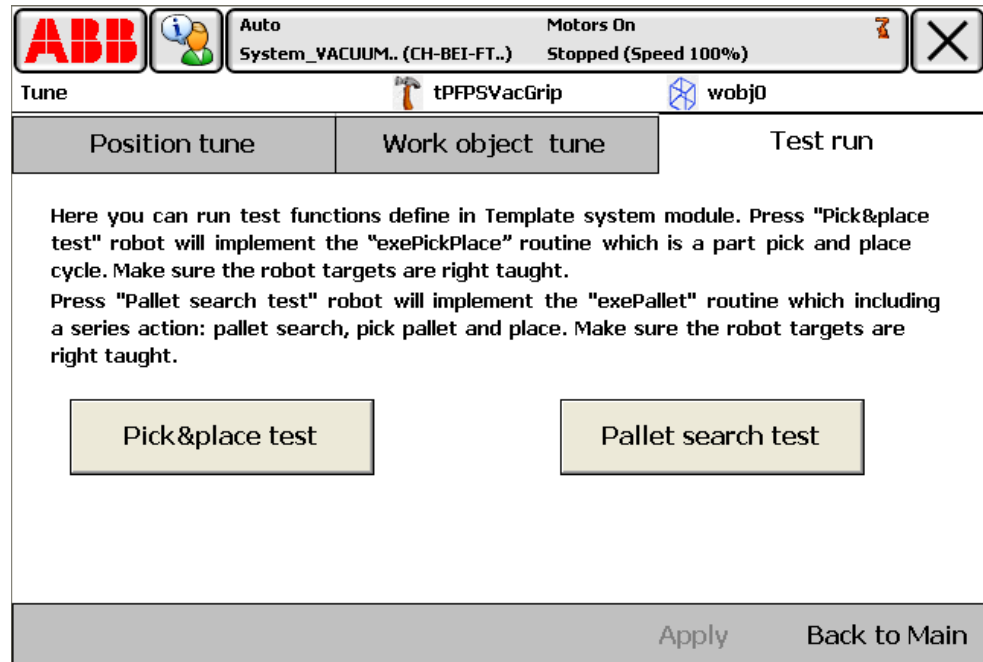

en1011065

3 FlexGripper UI

3.2.3.3. Test run

Continued

Press the Product Pick&place button, the robot implements the exePickPlace routing which includes a part pick and place cycle. Press the Pallet pick&place button, the robot will implement the exePallet routing which includes a series action: pallet search, pick pallet and place.



NOTE!

when pressing any of the test buttons, a message shows prompting you to press the run button. Press the run button. Before the test, the TCP should be edited according to the real payload in testrun.

In the pick operation and place operation, the loads of the FlexGripper are different. So the user must set the new TCP, payload and work object according to the different load situation.

For FlexGripper-Clamp (FlexGripper-Clamp 1, FlexGripper-Clamp 2) and FlexGripper-Claw, after entering the Test run interface:

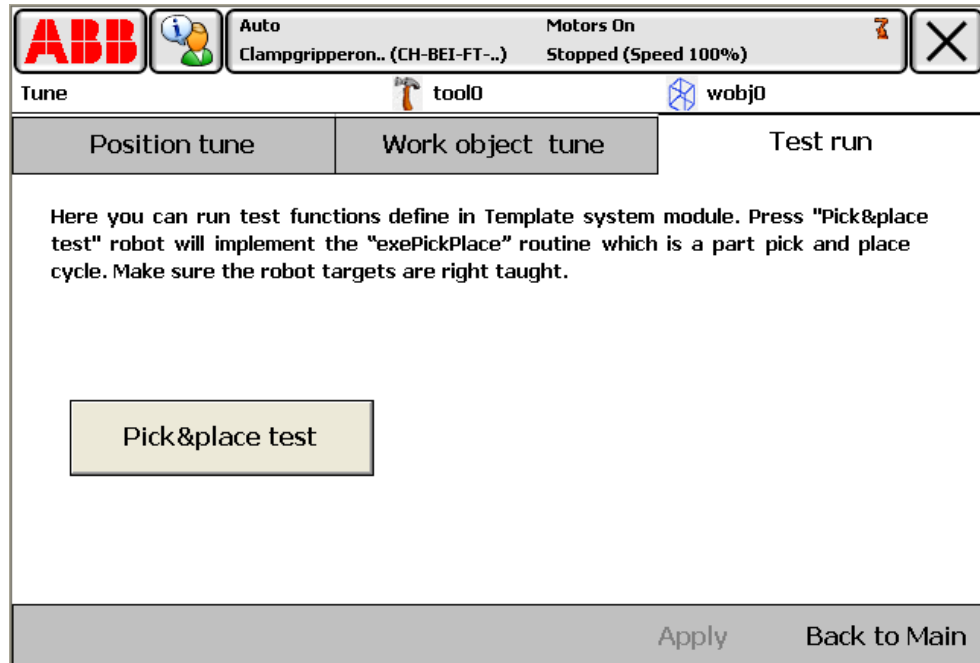

Press the Pick&place test button, the robot implements the exePickPlace routing which includes a part pick and place cycle.

Note: when pressing any of the test buttons, a message shows prompting you to press the run button. Press the run button. Before the test, the TCP should be edited according to the real payload in test run, and all the robot target positions must be accurate.

In the pick operation and place operation, the loads of the FlexGripper are different. So the user must set the new TCP, payload and work object according to the different load situation.

3.2.4. Production

3.2.4.1. Production monitor

The production interface shows monitor signals on the left and monitor variables on the right. Users can monitor the production by the status of signals and variables. Users can check if the signal status or variable status is correct. If it is not in the right condition, check the corresponding equipment.

3 FlexGripper UI

3.2.4.2. Setup

3.2.4.2. Setup

The production interface shows monitor signals on the left and monitor variables on the right. The monitoring signals and variables shown can be set by the Setup function.

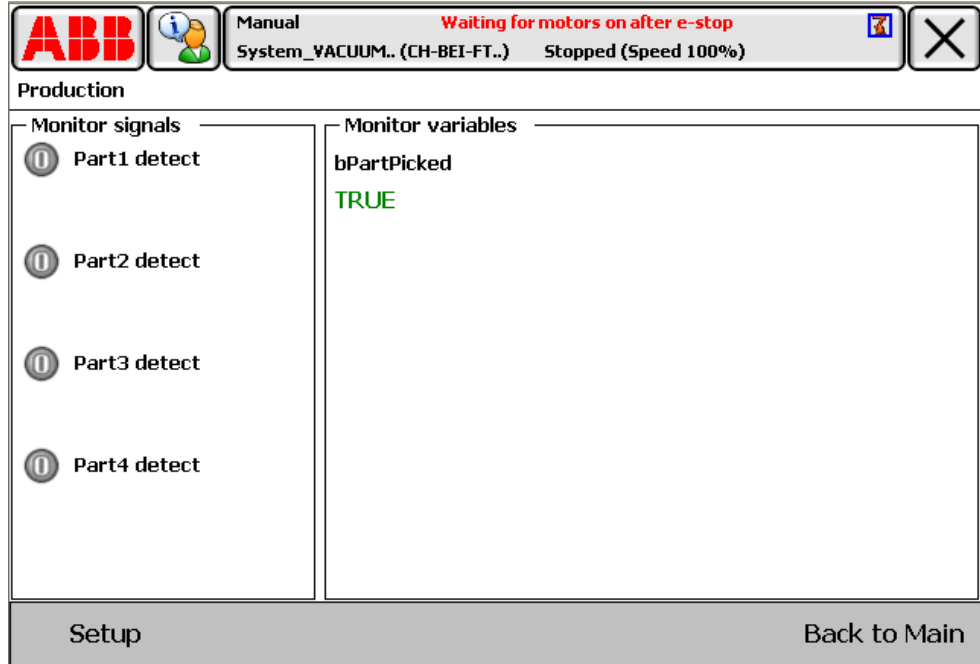

en1011067

Touch the Setup button, the following interface with signal list shows.

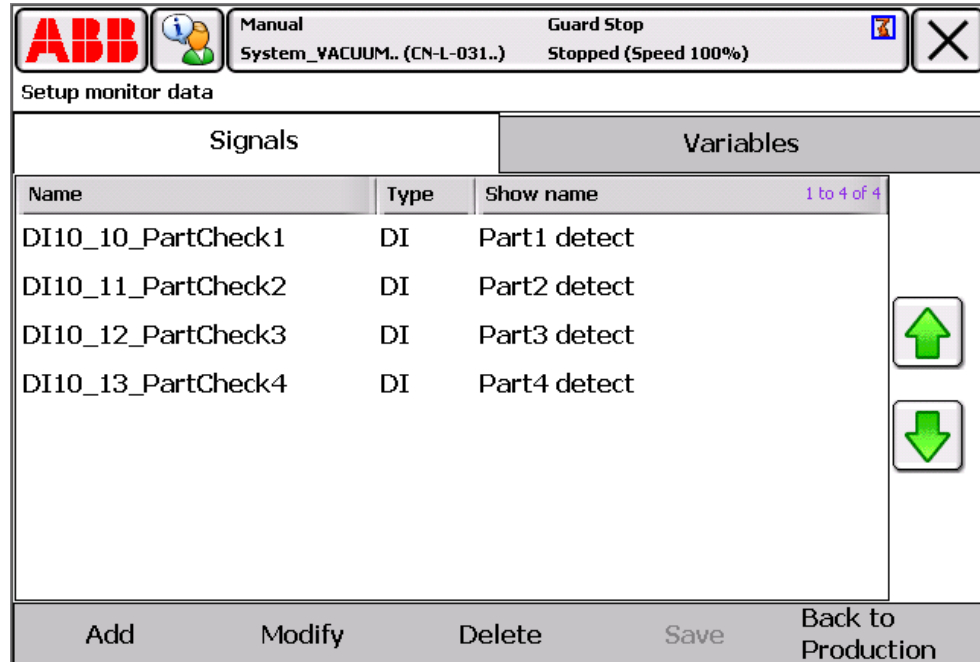

en1011068

Continues on next page

Continued

After selecting one of the signals, using the two arrows buttons (see picture above) on the right to choose former signals or signals below.

Use the yellow double triangle/single triangle buttons to go to the first/last page or to move the page up/down.

Signal edit

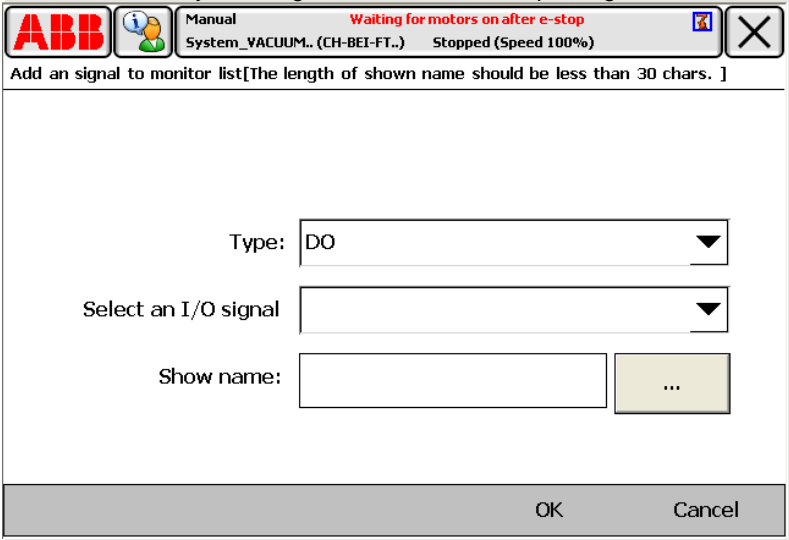
Action	Procedure
Add signal	<p>Touch Add button, then choose signal type, the signal to be added and edit its shown name by touching the button with an ellipsis sign.</p>  <p>en1011073</p> <p>A soft keyboard shows. Choose signal type for the signal to be added, edit its name by touching the button with an ellipsis. Type in the signal name. The signal name should be no longer than 25 characters which can only include numbers, letters and underline sign. Note: No more than 12 signals can be added.</p>
Modify signal	<p>Select the signal to be modified and press the Modify button. You can then modify its type, signal and name in the dropdown list or the soft keyboard. Press cancel if no modification is needed.</p>
Delete signal	<p>Select the signal to be deleted and press delete. The signal is then deleted from the monitor signal list.</p>

Continues on next page

Continued

Variable edit

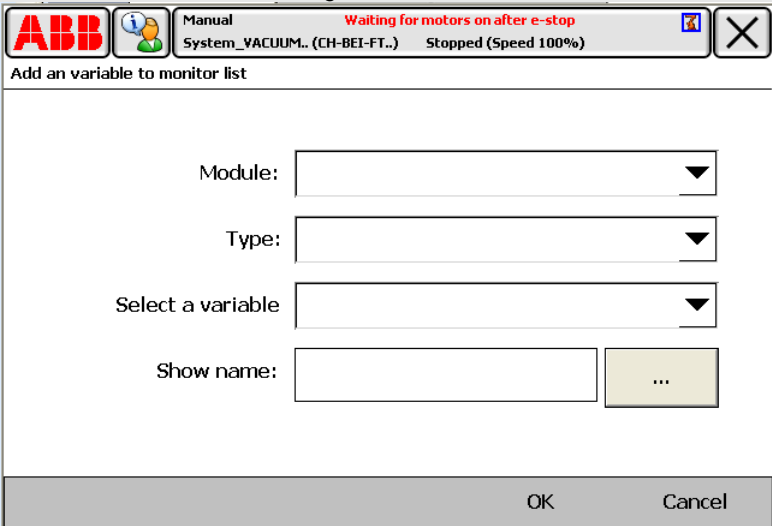
Action	Procedure
Add variable	<p>Touch Add button, the following interface shows:</p>  <p>en1011074</p> <p>Choose the module followed by the variable type to be added from the dropdown list. You can edit its name by selecting the button with the ellipsis. A soft keyboard shows with which you can enter the variable name.</p> <p>Note: The variable shown name should be no longer than 25 characters which can include numbers, letters and the underline sign.</p> <p>Note: No more than 12 variables can be added.</p>
Modify variable	<p>Select the variable to be modified and press the modify button. The variable, its module, type and name can be modified in the drop dropdown list or by using the soft keyboard. Select cancel if no modification is needed.</p>
Delete variable	<p>Select the variable to be deleted and press delete. The variable is deleted from the monitor variable list.</p>

When you have finished editing, select Save to save any changes. Press the Back to Production button to return to the Production main interface.

NOTE!

The variable configuration includes three elements: TASK, Storage type and Scope.

Their scopes are:

Task: T_ROB1;

Scope: Global, Task and local

Storage type: only Persistent

If the scope and storage type of the variable is not correct it can not be monitored.



3.3. Trouble shooting

Variable can not be monitored

Description	Can not monitor the variables
Possible reason	<ul style="list-style-type: none"> The scope of variable is not correct The storage type of variable is not correct
Solution	<ul style="list-style-type: none"> Make sure the variable and the storage type are correct

The valid scope of variables is:

Task: T_ROB1;

Scope: Global, Task and local

Storage type: Persistent

TCP can not be edited

Description	Can not edit the TCP
Possible reason	<ul style="list-style-type: none"> The scope of the TCP is not correct The storage type of the TCP is not correct
Solution	<ul style="list-style-type: none"> Make sure the scope and the storage type are correct

The valid scope of TCP is:

Task: T_ROB1;

Scope: Global, Task and local

Storage type: Persistent and Variable

Robot target can not be edited

Description	Can not edit the robot target
Possible reason	<ul style="list-style-type: none"> The scope of the robot target is not correct The storage type of the robot target is not correct
Solution	<ul style="list-style-type: none"> Make sure the scope and the storage type are correct

The valid scope of robot target is:

Task: T_ROB1;

Scope: Global, Task and local

Storage type: Persistent and Variable

Work object can not be edited

Description	Can not edit the work object
Possible reason	<ul style="list-style-type: none"> The scope of the work object is not correct The storage type of the robot target is not correct
Solution	<ul style="list-style-type: none"> Make sure the scope and the storage type are correct

Continues on next page

3 FlexGripper UI

3.3. Trouble shooting

Continued

The valid scope of the work object is:

Task: T_ROB1;

Scope: Global, Task

Storage type: Persistent and Variable

FlexGripper UI icon can not be displayed on the ABB main menu of the FlexPendant

Description	Can not display FlexGripper UI icon on FlexPendant
Possible reason	<ul style="list-style-type: none">• The FlexGripper UI FlexPendant application is installed incorrectly.• The FlexPendant Interface option is not selected when creating a robot system.
Solution	Check if the FlexGripper UI option is selected for the current system from ABB main menu->SystemInfo->SystemProperties->Additional Option on the FlexPendant. If the option is not displayed in the list, reinstall the TrueView application.

Position out of reach

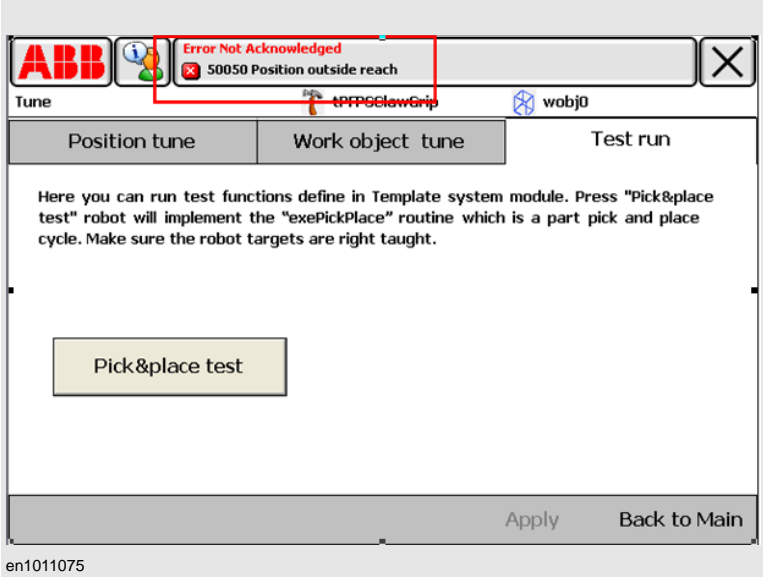
Description	 <p>The screenshot shows the ABB FlexPendant interface. At the top, there is a status bar with the ABB logo, a globe icon, and a red error message box that says "Error Not Acknowledged" and "50050 Position outside reach". Below the status bar, there are three tabs: "Position tune", "Work object tune", and "Test run". The "Test run" tab is selected, and it contains a text area with instructions: "Here you can run test functions define in Template system module. Press 'Pick&place test' robot will implement the 'exePickPlace' routine which is a part pick and place cycle. Make sure the robot targets are right taught." Below the text area is a button labeled "Pick&place test". At the bottom of the interface, there are two buttons: "Apply" and "Back to Main". The text "en1011075" is visible at the bottom left of the screenshot.</p>
Possible reason	Robot target position is out of reach of the robot.
Solution	Check and change the robot target position to a valid scope.

Continues on next page

Continued

Active view no valid test view

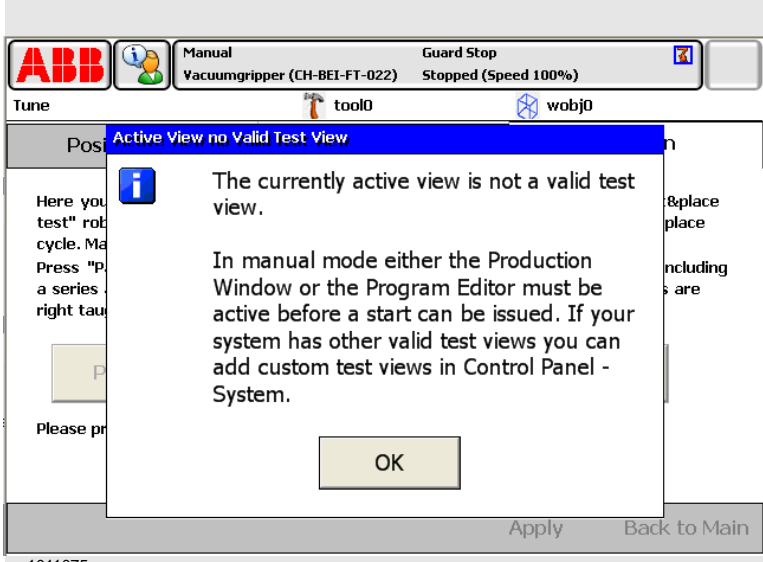
Description	
Possible reason	The current test view is not a valid test view.
Solution	Enter Control panel->Flexpendant-> AdditionalTestView, check if the test view of the FlexGripper UI is selected.

Two many views

Description	When all the 6 places of the task bar are occupied by views, a warning message box will pop up when clicking on the GUI icon.
Possible reason	Too many views are opened at the same time.
Solution	Close one or more of the views not in use.

Duplicated address

Description	
Possible reason	Two I/O units with the same addresses name 'BOARD10'.

Continues on next page

3 FlexGripper UI

3.3. Trouble shooting

Continued

Solution	Enter Control panel->Configuration-> Unit->BOARD10, edit the addresses name to BOARD11.
	Before software installation, edit the content 'DN_Address 10' to 'DN_Address 11' in EIO.cfg. For example, C:\Program Files\ABB Industrial IT\Robotics IT\MediaPool\FlexGripperUI\System\Clamp\EIO.cfg.



ABB Robotics
S-721 68 VÄSTERÅS
SWEDEN
Telephone: +46 (0) 21 344000
Telefax: +46 (0) 21 132592

3HAC040630-002, Revision -, en